



Füllstand



Druck



Durchfluss



Temperatur



Flüssigkeits-
analyse



Registrierung



Systeme
Komponenten



Services



Solutions

Technical information

Deltapilot S FMB70

Hydrostatic Level Measurement

Pressure sensor with the CONTITE™ measuring cell,
condensate proofed and long-term stable; Communication via
HART, PROFIBUS PA or FOUNDATION Fieldbus



Application

The hydrostatic pressure sensor is used for the following measuring tasks:

- Hydrostatic pressure measurement in liquids and paste media in all areas of process engineering, process measuring technology, pharmaceuticals and the food industries
- Level, volume or mass measurements in liquids

Your benefits

- Very good reproducibility and long-term stability
- Hermetically sealed CONTITE™ measuring cell:
 - condensate and climatic proofed
 - Maximum linearity (better than 0.1 % of the set measuring range)
 - High reference accuracy: $\pm 0.1\%$
 - Minimum temperature effects (better than 0.1%/10 K).
- HistoROM®/M-DAT memory module
- Function-monitored from the measuring cell to the electronics
- Quick commissioning thanks to quick setup menus
- Easy and safe menu-guided operation on-site, via 4 to 20 mA with HART, via PROFIBUS PA or via FOUNDATION Fieldbus
- Extensive diagnostic functions

Table of contents

Function and system design	4	Accuracy	20
Device selection	4	Reference operating conditions	20
Overview of process connections on FMB70	5	Long-term stability	20
Measuring principle	6	Influence of the installation position	20
Level measurement in closed tanks with pressure overlay	7	Reference accuracy	20
Density measurement	7	Total performance	20
Communication protocol	8	Warm-up period	20
Human interface	9	Dead time, Time constant (T63)	21
On-site display (optional)	9	Thermal change of the zero output and the output span	21
Operating elements	10	Operating conditions (installation)	22
HistoROM®/M-DAT (optional)	11	General installation instructions	22
Functional Safety SIL2/IEC 61508 Declaration of conformity (optional)	11	Wall and pipe mounting	22
On-site operation	11	Rotating the housing	22
Handheld terminals – HART	11	Oxygen applications	23
Handheld terminal DXR375 – FOUNDATION Fieldbus	11	Diaphragm seals for materials with hydrogen build-up (Gold-rhodium coating)	23
ToF Tool – HART, PROFIBUS PA, FOUNDATION Fieldbus	12	Operating conditions (environment)	24
FieldCare – HART, PROFIBUS PA	12	Ambient temperature limits	24
Remote operation – FOUNDATION Fieldbus	12	Storage temperature range	24
FXA193 service interface	12	Degree of protection	24
Input	13	Climate class	24
Measured variable	13	Electromagnetic compatibility	24
Measuring range	13	Overvoltage protection (optional)	24
Explanation of terms	13	Operating conditions (process)	25
Output	15	Process temperature limits	25
Output signal	15	Pressure specifications	25
Signal range – 4 to 20 mA HART	15	Mechanical construction	26
Signal on alarm	15	Dimensions of T14 housing	26
Load – 4 to 20 mA HART	15	Dimensions of T15 housing	26
Resolution	16	Dimensions of T17 housing	26
Reading cycle	16	Process connections	27
Cycle time (update time)	16	Weight	31
Response time	16	Material	32
Damping	16	Certificates and approvals	33
Power supply	17	CE mark	33
Electrical connection	17	Ex approvals	33
Supply voltage	19	Overfill protection	33
Current consumption	19	Standards and guidelines	33
Cable entry	19	Ordering information	34
Cable specification	19	FMB70	34
Residual ripple	19		
Influence of power supply	19		

Accessories	37
Welding flanges	37
Welding neck for universal process adapter	37
Welding neck for ISO G 1 1/2 thread	38
Adapter	38
HistoROM®/M-DAT	38
Mounting bracket	38
M 12x1 plug sockets	38
Documentation	39
Innovation	39
Field of activities	39
Technical information	39
Operating instructions	39
Functional safety manual (SIL)	39
Safety instructions	39
Installation/Control Drawings	39
Overfill protection	39



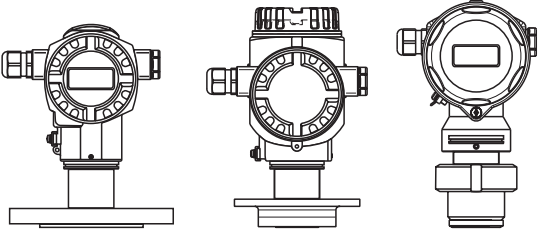

Function and system design

Device selection

Deltapilot S	FMB70
	
Field of application	<ul style="list-style-type: none"> - Level measurement - Hydrostatic pressure measurement
Industries	Food, pharmaceutical, environment (fresh water and wastewater), chemical
Process connections	<ul style="list-style-type: none"> - Thread - Flanges - Flush-mounted hygienic connections
Process connection material	<ul style="list-style-type: none"> - AISI 316L/1.4435 - Alloy C276/2.4819
Measuring ranges	from -100 to +100 mbar to -900 to +10000 mbar
OPL ¹	max. 27 bar
Process temperature range	-10 to +100°C/+14 to +212°F (+135°C/+275°F short term, for no more than 30 minutes)
Ambient temperature range	-40 to +85°C (-40 to +185°F)
Reference accuracy	±0.1%
Supply voltage	<ul style="list-style-type: none"> - 4 to 20 mA HART: 10.5 to 45 V DC, EEx ia: 10.5 to 30 V DC - PROFIBUS PA: 9 to 32 V DC - FOUNDATION Fieldbus: 9 to 32 V DC
Output	4 to 20 mA with overlaid HART protocol, PROFIBUS PA or FOUNDATION Fieldbus
Options	<ul style="list-style-type: none"> - Gold-rhodium coated diaphragm - 3.1 Inspection certificate - 3A and EHEDG approval
Specialties	<ul style="list-style-type: none"> - Absolutely resistant to condensate thanks to hermetically sealed CONTITE™ cell - Maximum flexibility thanks to modular design

1) OPL: Over Pressure Limit; depends on the weakest link in terms of pressure of the selected components

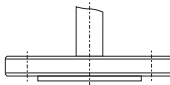
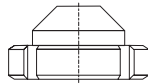
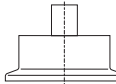
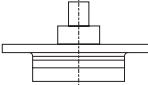
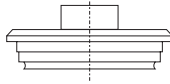
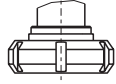
Overview of process connections on FMB70

Design	Connection	Version	Standard	Approval	Nominal diameter	Nominal pressure/Class
Thread	G	 P01-PMP75xxx-03-xx-xx-xx-005	ISO 228	—	G 1 1/2 A	40 bar
	NPT	 P01-PMP75xxx-03-xx-xx-xx-006	ANSI	—	1 1/2 MNPT	40 bar
Flange	EN/DIN flange	 P01-PMP75xxx-03-xx-xx-xx-001	EN 1092-1/ DIN 2527	—	– DN 40 – DN 50 – DN 80 – DN 100	PN 10/16
	ANSI flange		ANSI B 16.5	—	– 1 1/2" – 2" – 3" – 4"	150 lbs
	JIS flange		B 2220	—	– 25 A – 50 A – 80 A – 100A	10 K
Hygienic connections	Taper adapter with coupling nut	 P01-FMD78xxx-03-xx-xx-xx-003	DIN 11851	– EHEDG – 3A	– DN 40 – DN 50	PN 25
	Clamp	 P01-FMD78xxx-03-xx-xx-xx-005	ISO 2852	– EHEDG – 3A	– DN 51 (2")	Dependent on the clamp used
	DRD	 P01-FMD78xxx-03-xx-xx-xx-006		– 3 A	d = 65 mm	PN 25
	Varivent	 P01-FMD78xxx-03-xx-xx-xx-007		– EHEDG – 3 A	Type N for DN 40 – DN 162 pipes	PN 40
	SMS	 P01-FMB70xxx-03-xx-xx-xx-001		– EHEDG – 3A	2"	PN 25
	IDF	 P01-FMB70xxx-03-xx-xx-xx-002		– EHEDG – 3 A	2"	PN 25
	– Universal process adapter – Universal process adapter with 6" extension	 P01-FMB70xxx-03-xx-xx-xx-000		– EHEDG – 3A	d = 43.5 mm	PN 10

Measuring principle

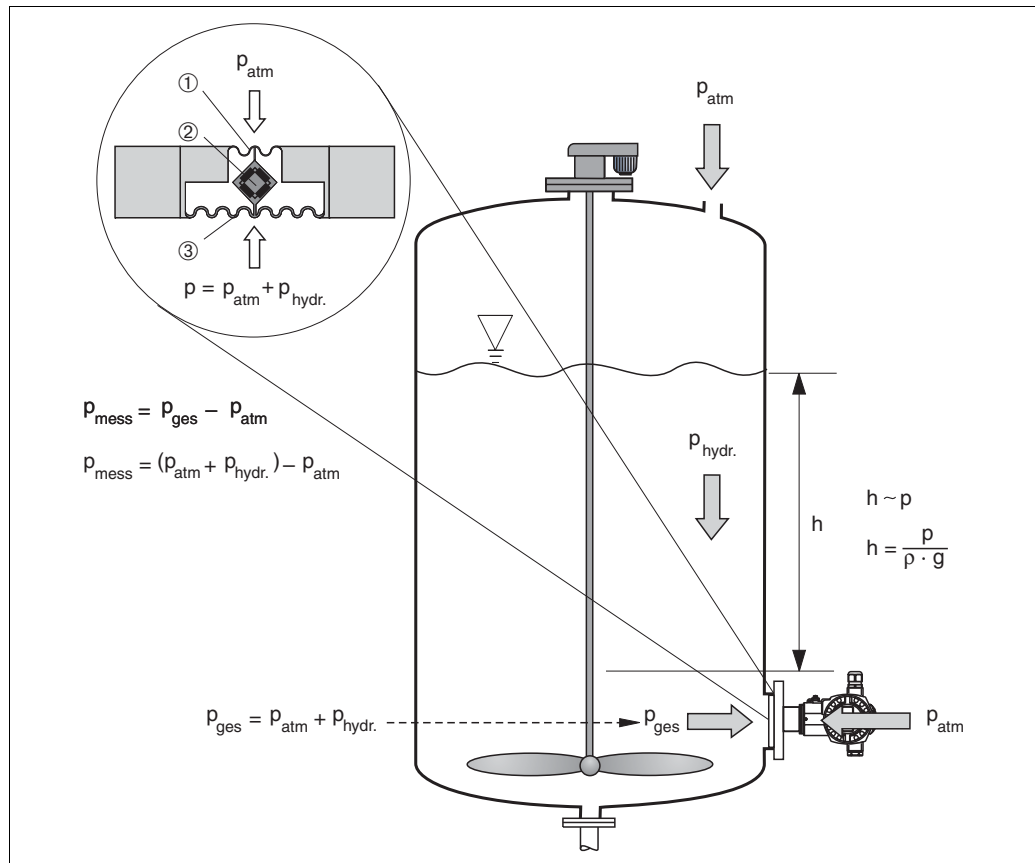

Deltapilot S hydrostatic level measurement and measuring principle

- 1 Measuring diaphragm
- 2 Measuring element
- 3 Process diaphragm (separating diaphragm)
- g Gravitational acceleration
- h Level height
- p_{tot} Total pressure = hydrostatic pressure + atmospheric pressure
- p_{atm} Atmospheric pressure
- $p_{hydr.}$ Hydrostatic pressure
- p_{meas} Measured pressure in the measuring cell = hydrostatic pressure
- ρ Density of fluid

Due to its weight, a liquid column creates hydrostatic pressure. If the density is constant, the hydrostatic pressure depends solely on the height h of the liquid column.

The CONTITE™ measuring cell which works on the principle of the gauge pressure sensor constitutes the core of Deltapilot S. In contrast to conventional gauge pressure sensors, the precision measuring element (2) in the CONTITE™ measuring cell is absolutely protected between the process diaphragm (3) and the measuring diaphragm (1). Thanks to this hermetic sealing of the measuring element, the CONTITE™ measuring cell is absolutely insensitive to condensate, condensation and aggressive gases. The pressure applied is transferred from the process diaphragm to the measuring element by means of an oil without any loss in pressure. Two temperature sensors are arranged between the process diaphragm and measuring element which measure the distribution of temperature in the cell. The electronics can compensate any measuring errors resulting from fluctuations in temperature with these measured temperature values.

Level measurement in closed tanks with pressure overlay

You can determine the differential pressure in tanks with pressure overlay using two Deltapilot S probes. The measured pressure values of the two probes are sent to a signal processing unit such as Endress+Hauser RMA or a PLC. The signal processing unit or PLC determines the difference in pressure and uses this to calculate the level and the density where necessary.

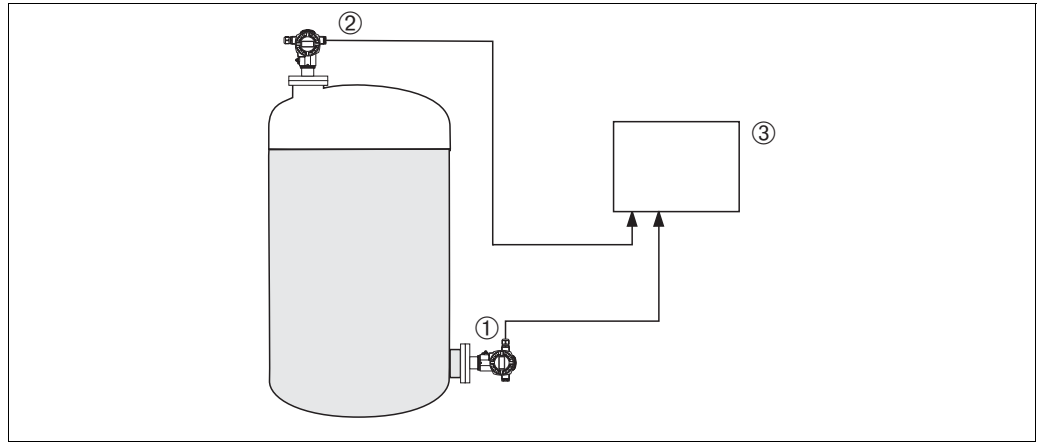

P01-FMB70xxx-15-xx-xx-xx-001

Level measurement in a closed tank with pressure overlay

- 1 Probe 1 measures the total pressure (hydrostatic pressure and top pressure)
- 2 Probe 2 measures the top pressure
- 3 The signal processing unit determines the difference in pressure and uses this to calculate the level

Note

- When selecting the Deltapilot S probes, make sure you select large enough measuring ranges (→ see example).
- The measuring diaphragm of probe 2 must not be flooded. This generates additional hydrostatic pressure which distorts the measurement.
- The ratio of hydrostatic pressure to top pressure should be no more than 1:6.

Example:

- Max. hydrostatic pressure = 600 mbar
- Max. top pressure (probe 2) = 300 mbar
- Max. total pressure, measured with probe 1 = 300 mbar + 600 mbar = 900 mbar
⇒ Measuring cell to be selected: 0 to 1200 mbar
- Max. pressure, measured with probe 2: 300 mbar
⇒ Measuring cell to be selected: 0 to 400 mbar

Density measurement

You can measure the density in tanks with pressure overlay using two Deltapilot S probes and a signal processing unit or a PLC. The signal processing unit or the PLC calculates the density from the known distance Δh between the two probes and the two measured values p_1 and p_2 .

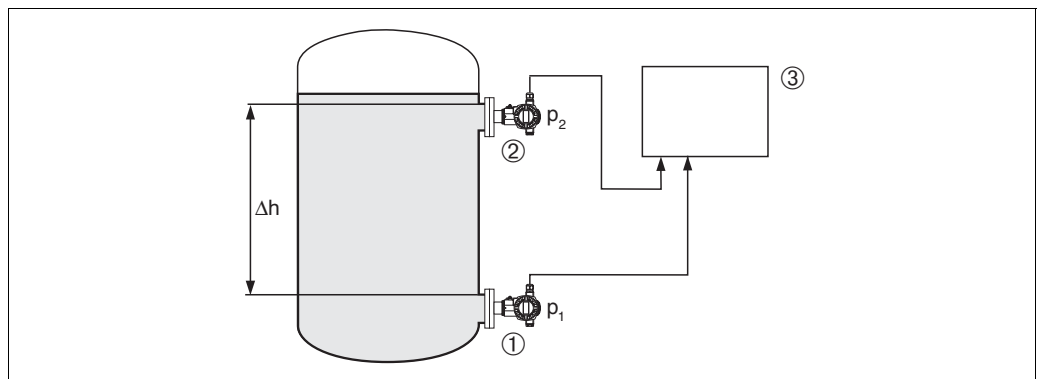

P01-FMB70xxx-15-xx-xx-xx-002

Level measurement in a closed tank with pressure overlay

- 1 Deltapilot S determines pressure measured value p_1
- 2 Deltapilot S determines pressure measured value p_2
- 3 Signal processing unit determines the density from the two measured values p_1 and p_2 and the distance Δh .

Communication protocol

- 4 to 20 mA with HART communication protocol
- PROFIBUS PA
 - The Endress+Hauser devices meet the FISCO model requirements.
 - Due to the low current consumption of $11\text{ mA} \pm 1\text{ mA}$, the following can be operated at one bus segment with installation as per FISCO:
 - Up to 9 Deltapilot S for EEx ia, CSA IS and FM IS applications
 - Up to 32 Deltapilot S for all other applications, e.g. in non-hazardous areas, EEx nA, etc.Further information on PROFIBUS PA can be found in Operating instructions BA034S "PROFIBUS DP/PA: Guidelines for planning and commissioning" and in the PNO guideline.
- FOUNDATION Fieldbus
 - The Endress+Hauser devices meet the FISCO model requirements.
 - Due to the low current consumption of $14\text{ mA} \pm 1\text{ mA}$, the following can be operated at one bus segment with installation as per FISCO:
 - Up to 7 Deltapilot S for EEx ia, CSA IS and FM IS applications
 - Up to 30 Deltapilot S for all other applications, e.g. in non-hazardous areas, EEx nA, etc.Further information on FOUNDATION Fieldbus such as bus system component requirements are provided in Operating instructions BA013S "FOUNDATION Fieldbus Overview".

Human interface

On-site display (optional)

A 4-line liquid crystal display (LCD) is used for display and operation. The on-site display shows measured values, dialog text as well as fault and notice messages in plain text, thereby supporting the user in every stage of operation.

4 to 20 mA HART

Functions:

- 8-digit measured value display including sign and decimal point, bargraph for current display
- Simple and complete menu guidance thanks to separation of the parameters into three levels
- Each parameter is given a 3-digit ID number for easy navigation.
- Option for configuring the display according to individual requirements and desires, such as language, alternating display, display of other measured values such as sensor temperature, contrast setting
- Comprehensive diagnostic functions (fault and warning message, peak-hold indicators, etc.)
- Rapid and safe commissioning with the Quick Setup menus

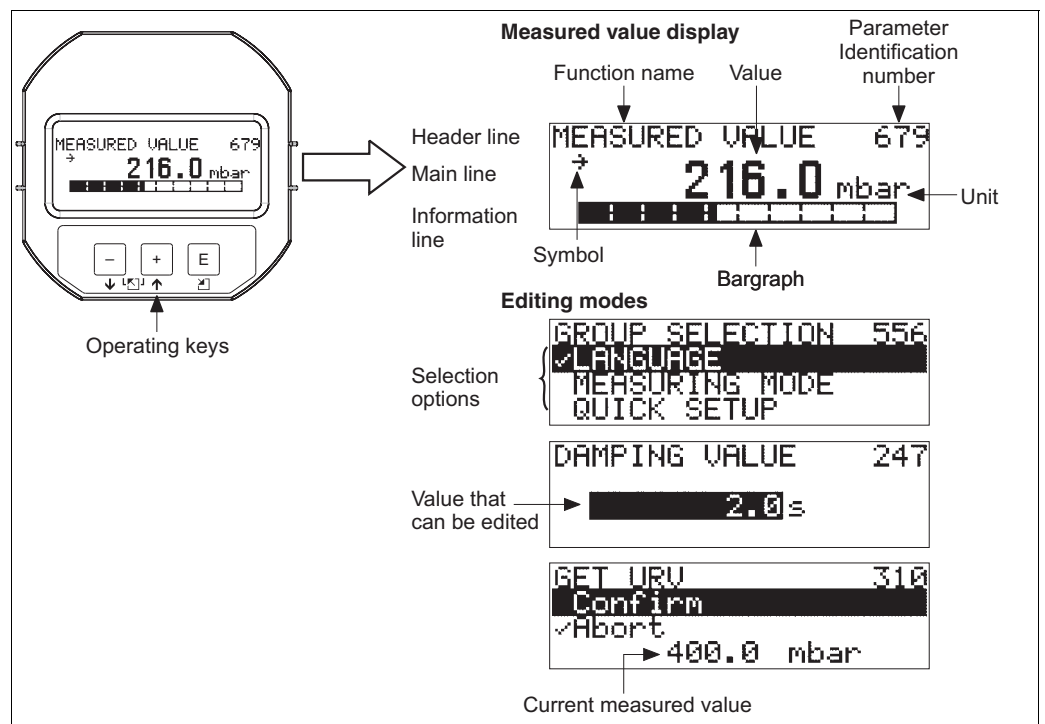

PROFIBUS PA and FOUNDATION Fieldbus

Functions:

- 8-digit measured value display including sign and decimal point, bargraph for current display
- Option for configuring the display according to individual requirements and desires, such as language, alternating display, display of other measured values such as sensor temperature, contrast setting
- Comprehensive diagnostic functions (fault and warning message)

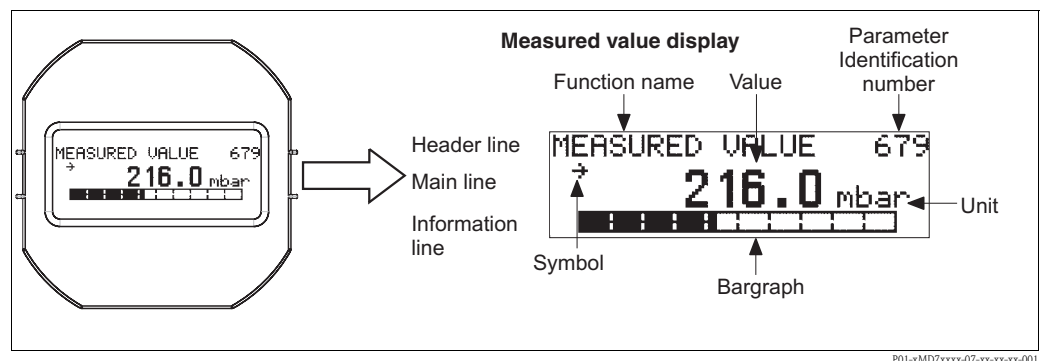

Operating elements

With regard to T14 and T15 housings, the operating keys are located either outside the device under the protection cap or inside on the electronic insert. In T17 housings, the operating keys are always located inside on the electronic insert.

In addition, devices with an on-site display and a 4 to 20 mA HART electronic insert have operating keys on the on-site display.

Operating keys on the exterior of the device

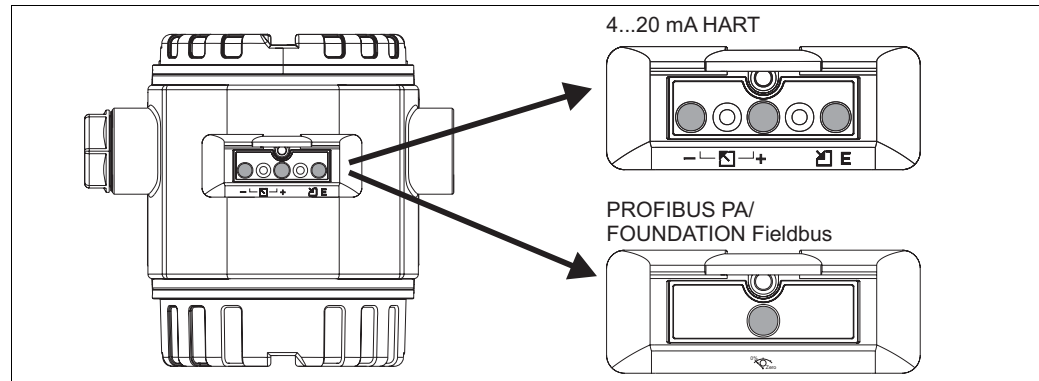

P01-PMx7xxxx-19-xx-xx-xx-038

The operating keys located externally on the device work on the Hall sensor principle. As a result, no additional openings are required in the device. This guarantees:

- Complete protection against environmental influences such as moisture and contamination
- Simple operation without any tools
- No wear.

Operating keys and elements located internally on the electronic insert

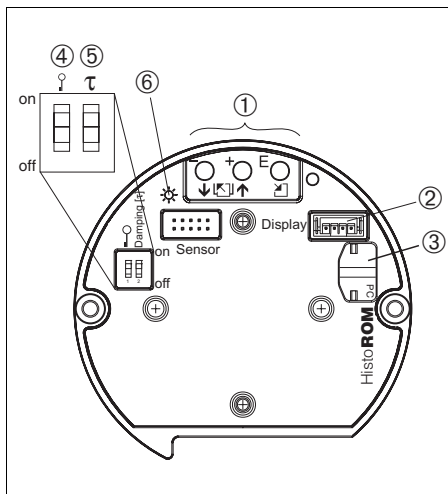

P01-xxxxxxx-19-xx-xx-xx-104

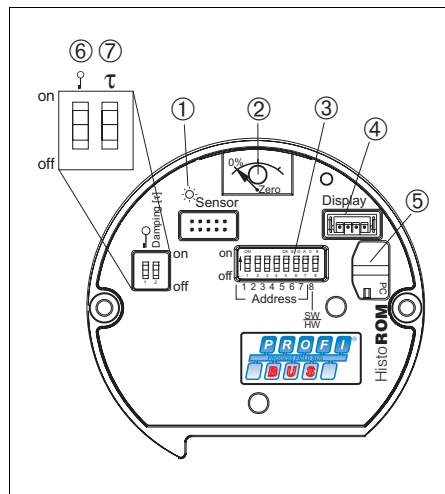

P01-xxxxxxx-19-xx-xx-xx-105

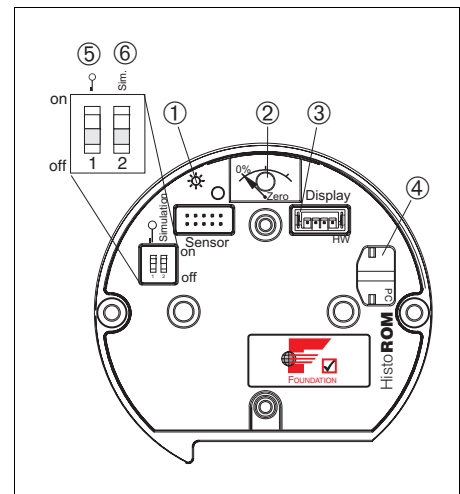

P01-xxxxxxx-19-xx-xx-xx-106

Electronic insert HART

- 1 Operating keys
- 2 Slot for optional display
- 3 Slot for optional HistoROM®/M-DAT
- 4 DIP-switch for locking/unlocking measured-value-relevant parameters
- 5 DIP-switch for damping on/off
- 6 Green LED to indicate value being accepted

Electronic insert PROFIBUS PA

- 1 Green LED to indicate value being accepted
- 2 Key for position calibration
- 3 DIP-switch for bus address
- 4 Slot for optional display
- 5 Slot for optional HistoROM®/M-DAT
- 6 DIP-switch for locking/unlocking measured-value-relevant parameters
- 7 DIP-switch for damping on/off

Electronic insert FOUNDATION Fieldbus

- 1 Green LED to indicate value being accepted
- 2 Key for position calibration
- 3 Slot for optional display
- 4 Slot for optional HistoROM®/M-DAT
- 5 DIP-switch for locking/unlocking measured-value-relevant parameters
- 6 DIP-switch for simulation mode on/off

HistoROM®/M-DAT (optional)

HistoROM®/M-DAT is a memory module, which is attached to the electronic insert. The HistoROM®/M-DAT can be retrofitted at any stage (Order number: 52027785).

Your benefits

- Quick and safe commissioning of the same measuring points by copying the configuration data of one transmitter to another transmitter
- Reliable process monitoring thanks to cyclical recording of pressure and sensor temperature measured values
- Simple diagnosis by recording diverse events such as alarms, configuration changes, counters for measuring range undershoot and overshoot for pressure and temperature as well as user limit overshoot and undershoot for pressure and temperature etc.
- Analysis and graphic evaluation of the events and process parameters via ToF Tool (contained in scope of supply)

HistoROM®/M-DAT can be ordered via feature 100 "Additional options 1" or feature 110 "Additional options 2" or as spare parts. → See also Page 35 ff. A CD with the Endress+Hauser ToF Tool operating program is also included in the scope of delivery.

You can copy data from one transmitter to another transmitter when operating a FOUNDATION Fieldbus device via an FF configuration program. You need the Endress+Hauser ToF Tool operating program and the FXA193 service interface to be able to access the data and events saved in the HistoROM®/M-DAT.

Functional Safety SIL2/IEC 61508 Declaration of conformity (optional)

The Deltapilot S hydrostatic pressure sensor with a 4 to 20 mA output signal have been developed to IEC 61508 standard. These devices can be used for process pressure monitoring up to SIL 2.
→ For a detailed description of the safety functions with Deltapilot S, settings and characteristic quantities for functional safety, please refer to the "Manual for Functional Safety - Deltapilot S" SD213P.
→ For devices with SIL2/IEC 61508 declaration of conformity, see Page 35 ff, Feature 100 "Additional option 1" and Feature 110 "Additional option 2", version E "SIL2/IEC 61508, Declaration of Conformity".

On-site operation**Functions 4...20 mA HART**

- With on-site display: navigate through the operating menu using three operating keys
- Without on-site display:
 - Position calibration (zero point correction)
 - Setting lower-range value and upper-range value – reference pressure present at device
 - Value acceptance indicated by green LED
- Device reset
- Locking and unlocking measured-value-relevant parameters
- Switching damping on and off

Functions PROFIBUS PA

- Position calibration (zero point correction)
- Value acceptance indicated by green LED
- Locking and unlocking measured-value-relevant parameters
- Setting bus address
- Switching damping on and off

Functions FOUNDATION Fieldbus

- Position calibration (zero point correction)
- Value acceptance indicated by green LED
- Locking and unlocking measured-value-relevant parameters
- Switching simulation mode on and off

Handheld terminals – HART

With a handheld terminal, all the parameters can be configured anywhere along the 4 to 20 mA line via menu operation.

Handheld terminal DXR375 – FOUNDATION Fieldbus

With a handheld terminal DXR375, all the parameters can be configured via menu operation.

**ToF Tool –
HART, PROFIBUS PA,
FOUNDATION Fieldbus**

The ToF Tool is a graphic and menu-guided operating program for measuring devices from Endress+Hauser. It is used for the commissioning, data storage, signal analysis and documentation of the devices. The following operating systems are supported: WinNT4.0, Win2000 and Windows XP. You can set all parameters via the ToF Tool.

The ToF Tool supports the following functions:

- Configuration of transmitters in online operation
- Loading and saving device data (upload/download)
- HistoROM®/M-DAT analysis
- Calculation of tank characteristics for the level measuring mode
- Documentation of the measuring point

Connection options:

- HART via Commubox FXA191 and the RS 232 C serial interface of a computer
- HART via Commubox FXA195 and the USB port on a computer
- PROFIBUS PA via segment coupler and PROFIBUS interface card
- FOUNDATION Fieldbus, PROFIBUS PA and HART via the FXA193 service interface



Note!

You can use the ToF Tool to configure the Endress+Hauser parameters for devices with "FOUNDATION Fieldbus signal". You need an FF configuration program to be able to configure all the FF-specific parameters and to integrate the device into an FF network.

**FieldCare –
HART, PROFIBUS PA**

FieldCare is an Endress+Hauser asset management tool based on FDT technology. With FieldCare, you can configure all Endress+Hauser devices as well as devices from other manufacturers that support the FDT standard. The following operating systems are supported: WinNT4.0, Win2000 and Windows XP.

FieldCare supports the following functions:

- Configuration of transmitters in offline and online operation
- Loading and saving device data (upload/download)
- HistoROM®/M-DAT analysis
- Documentation of the measuring point

Connection options:

- HART via Commubox FXA191 and the RS 232 C serial interface of a computer
 - HART via Commubox FXA195 and the USB port on a computer
 - PROFIBUS PA via segment coupler and PROFIBUS interface card
-

**Remote operation –
FOUNDATION Fieldbus**

An FF configuration program is required to integrate a device with "FOUNDATION Fieldbus signal" into an FF network or to set the FF-specific parameters. Please contact your local Endress+Hauser Sales Center for more information.

FXA193 service interface

The FXA193 service interface connects Deltapilot S, Cerabar S, Deltabar S, ToF and PROline measuring devices (level and flow measuring devices) with the RS 232 C serial interface of a PC and thus makes it possible to operate the measuring devices with the Endress+Hauser ToF Tool operating program. The FXA193 service interface is connected to the interface for the local display on the electronic insert. → See also graphics Page 10.

Input

Measured variable Hydrostatic pressure

Measuring range

Nominal value	Measurement limit		Span		OPL ¹ [bar]	MWP ² [bar]	Vacuum resistance ³ Polyalphaolefin/inert oil [bar _{abs}]	Version in the order code ⁴
	lower (LRL) ⁵ [bar]	upper (URL) [bar]	recommended min./max. [bar]	smallest calibratable [bar]				
100 mbar	-0.1	+0.1	0.05/0.1	0.01	2.7	4	0.01/0.04	1C
400 mbar	-0.4	+0.4	0.04/0.4	0.04	5.3	8	0.01/0.04	1F
1.2 bar	-0.9	+1.2	0.4/1.2	0.1	16	24	0.01/0.04	1H
4 bar	-0.9	+4	1.0/4.0	0.4	16	25	0.01/0.04	1M
10 bar	-0.9	+10	4.0/10	1.0	27	40	0.01/0.04	1P

- 1) OPL: over pressure limit
- 2) The MWP (maximum working pressure) for the measuring device depends on the weakest element of the components selected with regard to pressure, i.e. the process connection (→ see Page 26 ff) has to taken into consideration in addition to the sensor (→ see Table above). Pay attention to the pressure-temperature dependence also. For the appropriate standards and further information, see Page 25, "Pressure specification".
- 3) The vacuum resistance applies for the measuring cell under reference operating conditions.
- 4) → See also Page 34 ff, "Ordering information" chapter, feature 40 "Measuring range"
- 5) By default, the device is set to a low sensor limit of 0 bar. Please specify in the order if the low sensor limit is to be set to a different default value.

Explanation of terms

Explanation of terms: Turn down (TD), set span and span based on zero point

Case 1:

- $| \text{Lower range value} | \leq | \text{Upper range value} |$

Example:

- Lower range value = 0 mbar
- Upper range value = 40 mbar
- Nominal value = 400 mbar

Turn down:

- $\text{Nominal value} / | \text{Upper range value} |$
= 400 mbar/40 mbar
TD = 10:1

Set span:

- $\text{Upper range value} - \text{Lower range value} =$
40 mbar - 0 mbar
Set span = 40 mbar
This span is based on the zero point.

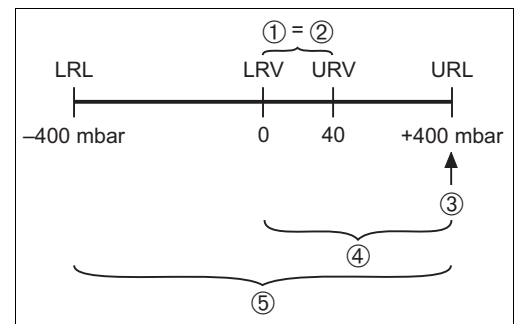

P01-DBxxxxxx-05-xx-xx-xx-001

Example: 400 mbar measuring cell

Case 2:

- $|\text{Lower range value}| \geq |\text{Upper range value}|$

Example:

- Lower range value = -200 mbar
- Upper range value = 0 bar
- Nominal value = 400 mbar

Turn down:

- $\text{Nominal value} / |\text{Lower range value}|$
= 400 mbar / 200 mbar
TD 2:1

Set span:

- $\text{Upper range value} - \text{Lower range value} =$
0 mbar - (-200 mbar)
Set span = 200 mbar
This span is based on the zero point.

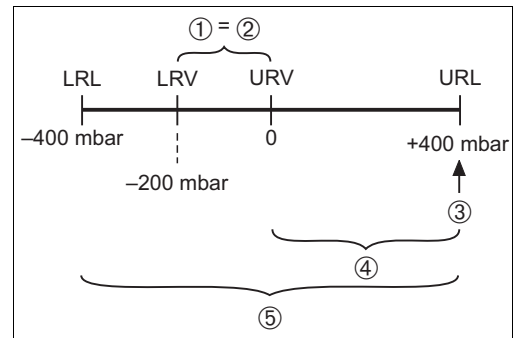
*Example: 400 mbar measuring cell*

- 1 Set span
- 2 Zero based span
- 3 Nominal value $\hat{=}$ upper range limit (URL)
- 4 Nominal measuring range
- 5 Sensor measuring range
- LRL Lower range limit
- URL Upper range limit
- LRV Lower range value
- URV Upper range value

Output

Output signal

- 4...20 mA with superimposed digital communication protocol HART 5.0, 2-wire
- Digital communication signal PROFIBUS PA (Profile 3.0)
- Digital communication signal FOUNDATION Fieldbus

Signal range – 4 to 20 mA HART

3.8 to 20.5 mA

Signal on alarm

- 4...20 mA HART
 - Options:
 - Max. alarm*: can be set from 21...23 mA
 - Keep measured value: last measured value is kept
 - Min. alarm: 3.6 mA
 - * Factory setting: 22 mA
- PROFIBUS PA: can be set in the Analog Input block,
 - options: Last Valid Out Value, Fsafe Value (factory setting), Status bad
- FOUNDATION Fieldbus: can be set,
 - options: Last good Value, Fail Safe Value (factory setting), Wrong Value

Load – 4 to 20 mA HART

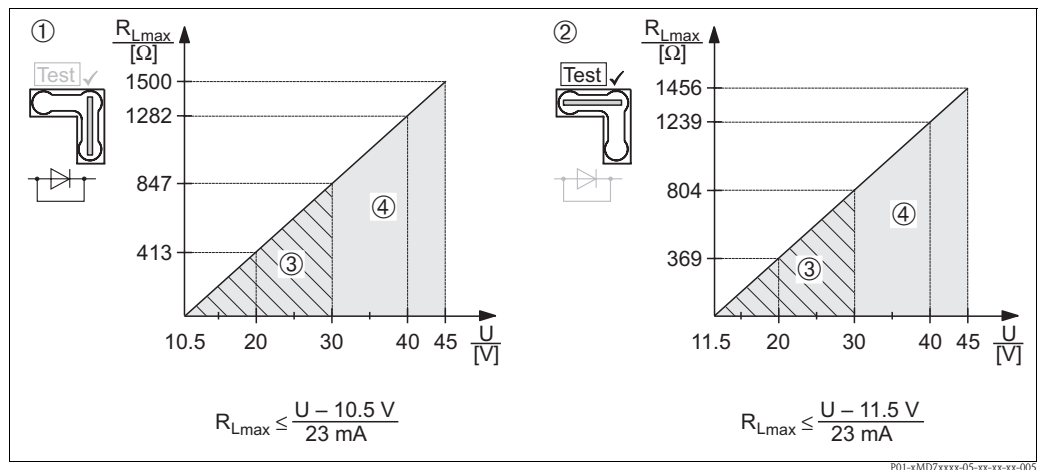

Load diagram, observe the position of the jumper and the explosion protection. (→ See also page 19, section "Taking 4...20 mA test signal".)

- 1 Jumper for the 4...20 mA test signal inserted in "Non-test" position
 - 2 Jumper for the 4...20 mA test signal inserted in "Test" position
 - 3 Supply voltage 10.5 (11.5) to 30 V DC for 1/2 G, 1 GD, 1/2 GD, FM IS, CSA IS and TIS Ex ia
 - 4 Supply voltage 10.5 (11.5) to 45 V DC for devices for non-hazardous areas, 1/2 D, 1/3 D, 3 G EEx nA, FM DIP, FM NI, CSA Dust-Ex
- R_{Lmax} Maximum load resistance
 U Supply voltage

Note!

When operating via a handheld terminal or via PC with an operating program, a minimum communication resistance of 250 Ω must exist within the loop.

Resolution	<ul style="list-style-type: none">■ Current output: 1 μA■ Display: can be set (setting at the factory: presentation of the maximum accuracy of the transmitter)
-------------------	---

Reading cycle	<ul style="list-style-type: none">■ HART commands: on average 3 to 4 per second■ PROFIBUS PA:<ul style="list-style-type: none">– Cyclic:<ul style="list-style-type: none">– max.: 100/s– typical value: 20/s– Acyclic:<ul style="list-style-type: none">– max.: 20/s– typical value: 10/s■ FOUNDATION Fieldbus:<ul style="list-style-type: none">– Cyclic: up to 5/s, dependent on the number and nature of the function blocks used in a closed-control loop– Acyclic: 10/s
----------------------	--

Cycle time (update time)	<p>PROFIBUS PA</p> <ul style="list-style-type: none">■ The cycle time in a bus segment in cyclic data communication depends on the number of devices, the segment coupler used and the internal PLC cycle time.■ The minimum cycle time is approx. 20 ms per device.
---------------------------------	---

Response time	<ul style="list-style-type: none">■ PROFIBUS PA:<ul style="list-style-type: none">– Cyclic: approx. 10 ms per request– Acyclic: < 50 ms■ FOUNDATION Fieldbus:<ul style="list-style-type: none">– Cyclic: < 80 ms– Acyclic: < 40 ms <p>All values are typical values.</p>
----------------------	--

Damping	<ul style="list-style-type: none">■ Via on-site display, handheld terminal or PC with operating program, continuous from 0...999 s■ Additionally for HART and PROFIBUS PA: via DIP-switch on the electronic insert, switch position "on" = set value and "off"■ Factory setting: 2 s
----------------	--

Power supply

Electrical connection

Note

- When using the measuring device in hazardous areas, installation must comply with the corresponding national standards and regulations and the Safety Instructions or Installation or Control Drawings.
→ See also Page 39 ff, "Safety Instructions" and "Installation/Control Drawings" sections.
- Devices with integrated overvoltage protection must be grounded. → See also Page 24.
- Protective circuits against reverse polarity, HF influences and overvoltage peaks are installed.

4 to 20 mA HART

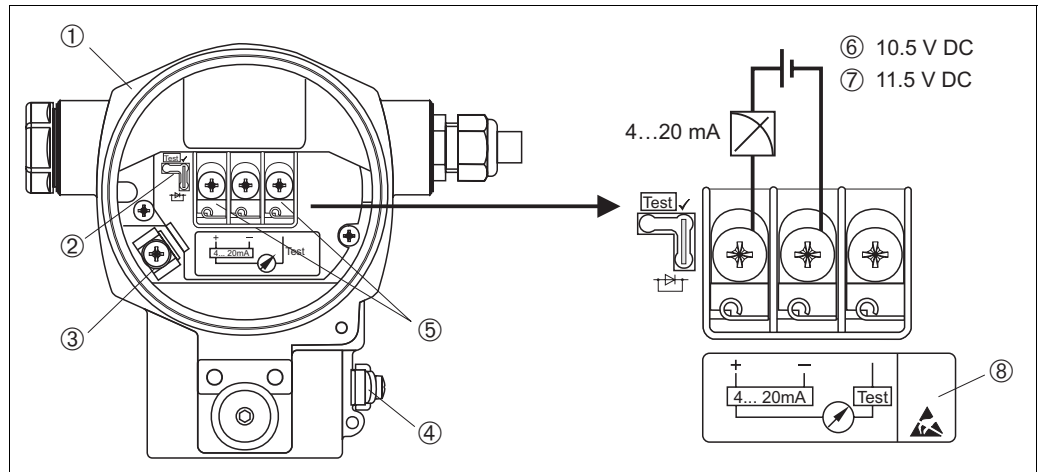

Electrical connection 4 to 20 mA HART, here shown with aluminum housing (T14)

- 1 Housing
- 2 Jumper for 4 to 20 mA test signal
→ See also Page 19, "Taking 4 to 20 mA test signal".
- 3 Internal ground terminal
- 4 External ground terminal
- 5 4 to 20 mA test signal between positive and test terminal
- 6 Minimum supply voltage 10.5 V DC, if the jumper is inserted in accordance with the illustration.
- 7 Minimum supply voltage 11.5 V DC, if the jumper is inserted in "Test" position.
- 8 Devices with integrated overvoltage protection are labelled OVP (overvoltage protection) here (→ see also Page 24).

PROFIBUS PA

The two-wire cable must be connected to the "PA+" and "PA-" terminals.

FOUNDATION Fieldbus

The two-wire cable must be connected to the "FF+" and "FF-" terminals.

Devices with Harting plug Han7D

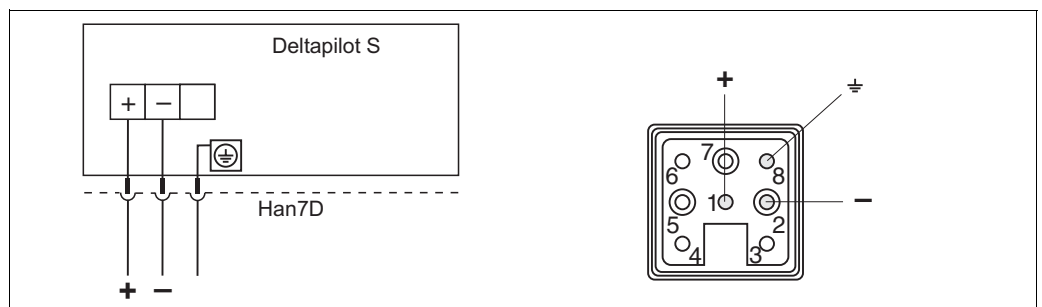

Left: electrical connection for devices with Harting plug Han7D
Right: view of the plug at the device

Devices with M12 plug

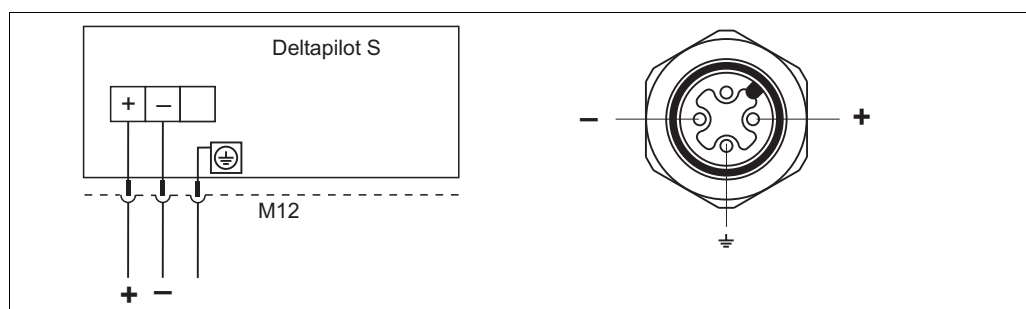

P01-FMB70xxx-04-xx-xx-xx-001

Left: electrical connection for devices with M12 plug
Right: view of the plug at the device

Endress+Hauser offers for devices with M12 plug the following accessories:

Plug-in jack M 12x1, straight

- Material: Body PA; coupling nut CuZn, nickel-plated
- Degree of protection (fully locked): IP67
- Order number: 52006263

Plug-in jack M 12x1, elbowed

- Material: Body PBT/PA; coupling nut GD-Zn, nickel-plated
- Degree of protection (fully locked): IP67
- Order number: 51006327

Cable 4x0.34 mm² with M12 socket, elbowed, screw plug, 5 m length

- Material: Body PUR; coupling nut CuSn/Ni; cable PVC
- Degree of protection (fully locked): IP67
- Order number: 52010285

Devices with 7/8" plug connector

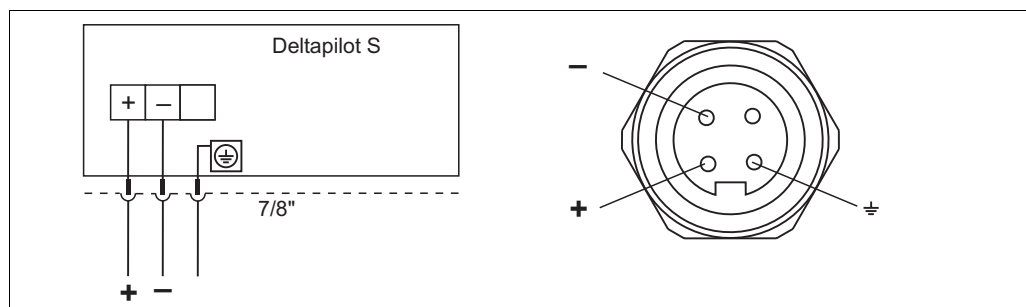



P01-FMB70xxx-04-xx-xx-xx-002

left: Electrical connection for devices with 7/8" plug connector
right: View of connector on device

Taking 4...20 mA test signal

A 4...20 mA signal may be measured via the positive and test terminal without interrupting the measurement. The minimum supply voltage of the device can be reduced by simply changing the position of the jumper. As a result, operation is also possible with lower voltage sources. Observe the position of the jumper in accordance with the following table.

Jumper position for test signal	Description
	<ul style="list-style-type: none"> - Taking 4...20 mA test signal via plus and test terminal: possible. (Thus, the output current can be measured without interruption via the diode.) - Delivery status - minimum supply voltage: 11.5 V DC
	<ul style="list-style-type: none"> - Taking 4...20 mA test signal via plus and test terminal: not possible. - minimum supply voltage: 10.5 V DC

Supply voltage**Note**

- When using the measuring device in hazardous areas, installation must comply with the corresponding national standards and regulations and the Safety Instructions or Installation or Control Drawings.
- All explosion protection data are given in separate documentation which is available upon request. The Ex documentation is supplied as standard with all devices approved for use in explosion hazardous areas. → See also Page 39 ff, "Safety Instructions" and "Installation/Control Drawings" sections.

4 to 20 mA HART

- Version for non-hazardous areas, jumper for 4 to 20 mA test signal in "Test" position (delivery status condition): 11.5 to 45 V DC
- Version for non-hazardous areas, jumper for 4 to 20 mA test signal in "Non-test" position 10.5 to 45 V DC

PROFIBUS PA

- Version for non-hazardous areas: 9 to 32 V DC

FOUNDATION Fieldbus

- Version for non-hazardous areas: 9 to 32 V DC

Current consumption

- PROFIBUS PA: 11 mA ± 1 mA, switch-on current corresponds to IEC 61158-2, Clause 21
- FOUNDATION Fieldbus: 14 mA ± 1 mA, switch-on current corresponds to IEC 61158-2, Clause 21

Cable entry

→ See also Page 34 ff, feature 30 "Housing; Cable entry; Degree of protection".

Cable specification

- Endress+Hauser recommends using shielded, shielded twisted-pair two-wire cables.
- Terminals for wire cross-sections 0.5 to 2.5 mm²
- Cable external diameter: 5 to 9 mm

Residual ripple

Without influence on 4 to 20 mA signal up to ± 5% residual ripple within the permitted voltage range [according to HART hardware specification HCF_SPEC-54 (DIN IEC 60381-1)]

Influence of power supply

≤ 0.0006 % of URL/1 V

Accuracy

Reference operating conditions

- As per IEC 60770
- Ambient temperature range T_A = constant, in the range of: +21 to +33°C (+69.8 to +91.4°F)
- Humidity φ = constant, in the range of: 5 to 80 % RH
- Ambient pressure p_A = constant, in the range of: 860 to 1060 mbar
- Position of measuring cell = constant, in the range of: horizontal $\pm 1^\circ$
- Input of LOW SENSOR TRIM and HIGH SENSOR TRIM for lower range value and upper range value
- Zero based span
- Membrane material: Alloy C276 (2.4819)
- Filling oil: mineral oil (polyalphaolefin)/inert oil
- Supply voltage: 24 V DC \pm 3 V DC
- Load with HART: 250 Ω

Long-term stability

- 100 mbar measuring cell: $\pm 0.18\%$ of URL/year
- 400 mbar, 1200 mbar measuring cell: $\pm 0.1\%$ of URL/year
- 4000 mbar, 10000 mbar measuring cell: $\pm 0.05\%$ of URL/year

Influence of the installation position

- Maximum: ± 2.3 mbar ¹⁾

1) This value is doubled for devices with inert oil.

Note

Position-dependent zero shift can be corrected. → See also Page 22, "General installation instructions" section.

Reference accuracy

The reference accuracy comprises the non-linearity including hysteresis and non-reproducibility in accordance with the limit point method in accordance with IEC 60770.

100 mbar measuring cell:

- TD 1:1 to TD 2:1: $\pm 0.15\%$ of the set span
- TD 2:1 to TD 4:1: $\pm 0.075\%$ of the set span x TD

400 mbar measuring cell:

- TD 1:1 to TD 4:1: $\pm 0.15\%$ of the set span
- TD 4:1 to 10:1: $\pm 0.0375\%$ of the set span x TD

1200 mbar measuring cell:

- TD 1:1 to TD 3:1: $\pm 0.1\%$ of the set span
- TD 3:1 to 10:1: $\pm 0.033\%$ of the set span x TD

4000 mbar measuring cell:

- TD 1:1 to TD 4:1: $\pm 0.1\%$ of the set span
- TD 4:1 to 10:1: $\pm 0.025\%$ of the set span x TD

10000 mbar measuring cell:

- TD 1:1 to TD 2,5:1: $\pm 0.1\%$ of the set span
- TD 2,5:1 to 10:1: $\pm 0.04\%$ of the set span x TD

Total performance

The total performance comprises the non-linearity including hysteresis, non-reproducibility as well as the thermal change of the zero point.

All specifications apply for the temperature range -10 to $+60^\circ\text{C}$ ($+14$ to $+140^\circ\text{F}$).

- 100 mbar, 400 mbar measuring cell: $\pm 0.35\%$ of URL
- 1200 mbar, 4000 mbar, 10000 measuring cell: $\pm 0.15\%$ of URL

Warm-up period

- 4 to 20 mA HART: < 10 s
- PROFIBUS PA: 6 s
- FOUNDATION Fieldbus: 50 s

**Dead time,
Time constant (T63)**

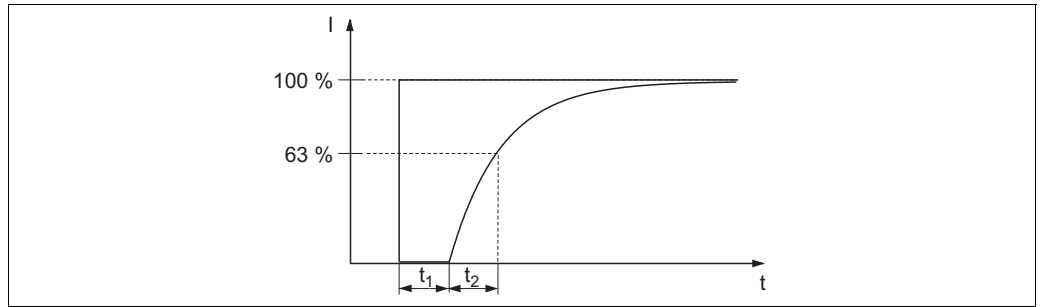

F01-xxxxxxx-05-xx-xx-xx-007

Presentation of the dead time and the time constant

Type	Dead time t_1	Time constant (T63), t_2
FMB70	40 ms	30 ms

**Thermal change of the zero
output and the output span**

-10 to +60°C (+14 to +140°F):

- 100 mbar measuring cell: $\pm(0.3 \times \text{TD} + 0,02)\%$ of the set span
- 400 mbar measuring cell: $\pm(0.25 \times \text{TD} + 0,01)\%$ of the set span
- 1200 mbar, 4000 mbar, 10000 mbar measuring cell: $\pm(0.1 \times \text{TD} + 0,01)\%$ of the set span

+60 to +85°C (+140 to +185°F):

- 100 mbar measuring cell: $\pm(0.4 \times \text{TD} + 0.04)\%$ of the set span
- 400 mbar measuring cell: $\pm(0.3 \times \text{TD} + 0.02)\%$ of the set span
- 1200 mbar, 4000 mbar, 10000 mbar measuring cell: $\pm(0.15 \times \text{TD} + 0.02)\%$ of the set span

Operating conditions (installation)

General installation instructions

- Always install the device under the lowest measuring point.
- Do not install the device at the following positions:
 - in the filling curtain
 - in the tank outflow
 - or at a point in the tank that can be reached by pressure pulses from the agitator.
- The calibration and functional test can be carried out more easily if you mount the device downstream of a shut-off device.
- Deltapilot S must be included in the insulation for media that can harden when cold.
- The orientation dependent zero point shift can be corrected directly on the device using an operating key, and even in a hazardous area on devices with external controls.
- The Deltapilot S housing can be rotated through up to 380°. → See also Page 22, "Rotating the housing" section.
- The on-site display can be rotated in 90° stages.
- Endress+Hauser offers a mounting bracket for installing the device on pipes or on walls.
 - See also Page 22, "Wall and pipe mounting" section.

Wall and pipe mounting

Endress+Hauser offers a mounting bracket for installing the device on pipes or on walls.
→ See also Page 36 ff, feature 110, "Additional options 2".

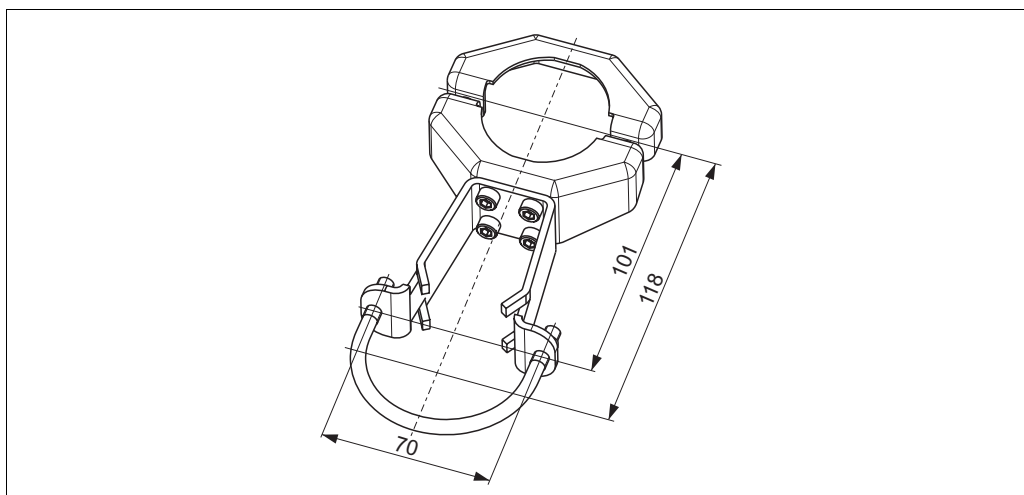

P01-PMx7xxxx-06-xx-xx-xx-001

Rotating the housing

The housing can be rotated through up to 380° by loosening the Allen screw.

Your benefits

- Simple mounting by optimally aligning the housing
- Good, accessible device operation
- Optimum readability of the on-site display (optional).

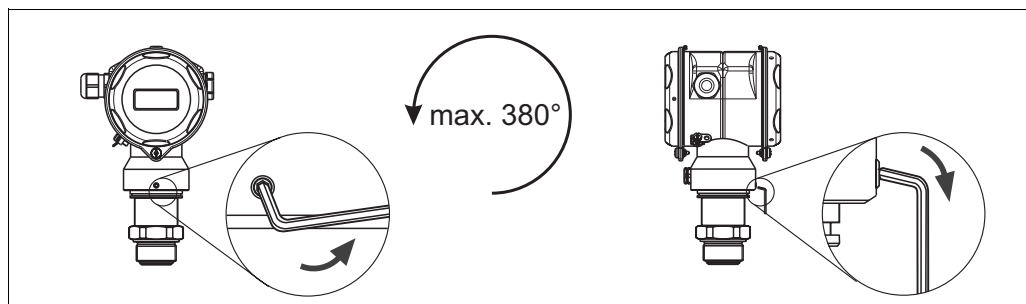

P01-FMB70xxx-17-xx-xx-xx-000

Align the housing by loosening the Allen screw.

Aluminum housing (T14 and T15): 2 mm Allen key; Stainless steel housing (T17): 3 mm Allen key

Oxygen applications

Oxygen and other gases can react explosively to oils, grease and plastics, such that, among other things, the following precautions must be taken:

- All components of the system, such as measuring devices, must be cleaned in accordance with the BAM (DIN 19247) requirements.
- Dependent on the materials used, a certain maximum temperature and a maximum pressure for oxygen applications must not be exceeded. The maximum temperature T_{max} for oxygen applications is 60°C (140°F).

The devices suitable for gaseous oxygen applications are listed in the following table with the specification p_{max} .

Order code for devices cleaned for oxygen applications	p_{max} for oxygen applications
FMB70 – * * * * * F * *	Depends on the weakest link in terms of pressure of the selected components: over pressure limit (OPL) of the selected sensor or process connection (1.5 x PN) ¹

1) → See Page 13, "Measuring range" and Page 26 ff, "Mechanical construction" section

Diaphragm seals for materials with hydrogen build-up (Gold-rhodium coating)

With regard to materials in which hydrogen build-up takes place, hydrogen atoms can diffuse through the metal diaphragms. This can result in incorrect measurement results.

Endress+Hauser offers diaphragms with Gold-Rhodium coating for this application.

→ See also Page 35 "FMB70 ordering information", feature 60 "Diaphragm material" version "6".

Operating conditions (environment)

Ambient temperature limits

- FMB70: -40 to +85°C (-40 to +185°F)
lower temperatures on request
- On-site display: -20 to +70°C (-4 to +158°F)
Extended operating temperature range with restrictions in the optical properties such as display speed and contrast: -40 to +85°C (-40 to +185°F)

For devices for use in hazardous areas, see Safety Instructions, Installation or Control Drawing.
→ See also Page 39 ff, "Safety Instructions" and "Installation/Control Drawing" sections).

The device can be used in this temperature range. The values in the specification, such as thermal changes, may be exceeded in this case.

Storage temperature range

- -40 to +100°C (-40 to +212°F)
- On-site display: -40 to +85°C (-40 to +185°F)

Degree of protection

- → See Page 34 ff, feature 30 "Housing; Cable entry; Degree of protection".
- Degree of protection IP 68 for T17 housing: 1.83 mH₂O for 24 hours

Climate class

Class 4K4H (air temperature: -20 to 55°C (-4 to +131°F), relative humidity: 4 to 100 %) fulfilled as per DIN EN 60721-3-4 (condensation possible)

Electromagnetic compatibility

- Interference emission as per EN 61326 electrical device B, Interference immunity as per EN 61326 appendix A (industrial use) and NAMUR EMC recommendation (NE 21).
- With enhanced interference immunity against electromagnetic fields in accordance with EN 61000-4-3: 30 V/m with closed lid¹
- Maximum deviation: < 0.5 % of span
- All measurements were performed with a turn down (TD) = 2:1.

1) measured for devices with aluminum housing (T14 and T15)

Overvoltage protection (optional)

- Overvoltage protection:
 - Nominal functioning DC voltage: 600 V
 - Nominal discharge current: 10 kA
- Surge current check $\hat{i} = 20$ kA as per DIN EN 60079-14: 8/20 μ s satisfied
- Arrester AC current check $I = 10$ A satisfied

→ See also page 35 ff, feature 100 "Additional options 1" and feature 110 "Additional options 2", version "M Overvoltage protection".

Note!

Devices with integrated overvoltage protection must be grounded.

Operating conditions (process)

Process temperature limits

- -10 to +100°C (+14 to +212°F)
 - Up to +135°C (+275°F) short-term (for a maximum of 30 minutes) for cleaning purposes
-

Pressure specifications

- The MWP (maximum working pressure) is specified on the nameplate. The maximum pressure for the measuring device is dependent on the lowest-rated element with regard to pressure, see the following sections for this:
 - → Page 13 ff, section "Measuring range"
 - → Chapter "Mechanical construction".The MWP (maximum working pressure) is specified on the nameplate. This value refers to a reference temperature of 20°C (68°F) or 100°F for ANSI flanges. Observe pressure-temperature dependency.
- The pressure values permitted at higher temperatures can be found in the following standards:
 - EN 1092-1: 2001 Tab. 18¹
 - ASME B 16.5a – 1998 Tab. 2-2.2 F316
 - ASME B 16.5a – 1998 Tab. 2.3.8 N10276
 - JIS B2238/2210
- The test pressure corresponds to the over pressure limit (OPL) of the device = MWP x 1.5.
- The Pressure Equipment Directive (EC Directive 97/23/EC) uses the abbreviation "PS". The abbreviation "PS" corresponds to the MWP (maximum working pressure) of the measuring device.
- In the case of sensor range and process connections where the OPL (Over pressure limit) of the pressure connection is smaller than the nominal value of the sensor, the device is set at the factory, at the very maximum, to the OPL value of the process connection. If you want to use the entire sensor range, select a process connection with a higher OPL value (1.5 x PN; PN = MWP).
- In oxygen applications, the values for "p_{max} and T_{max} for oxygen applications" as per Page 23, "Oxygen applications" may not be exceeded.

1) With regard to its stability property, the material 1.4435 is identical to 1.4404 which is grouped under 13EO in EN 1092-1 Tab. 18. the chemical composition of the two materials can be identical.

Mechanical construction

Dimensions of T14 housing

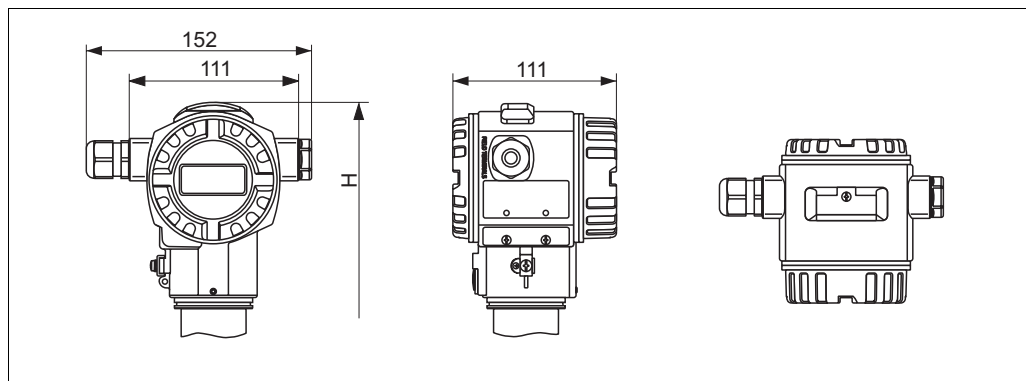

Front view, left-hand side view, top view.

→ See appropriate process connection for installation height H . For housing weight see Page 31.

Dimensions of T15 housing

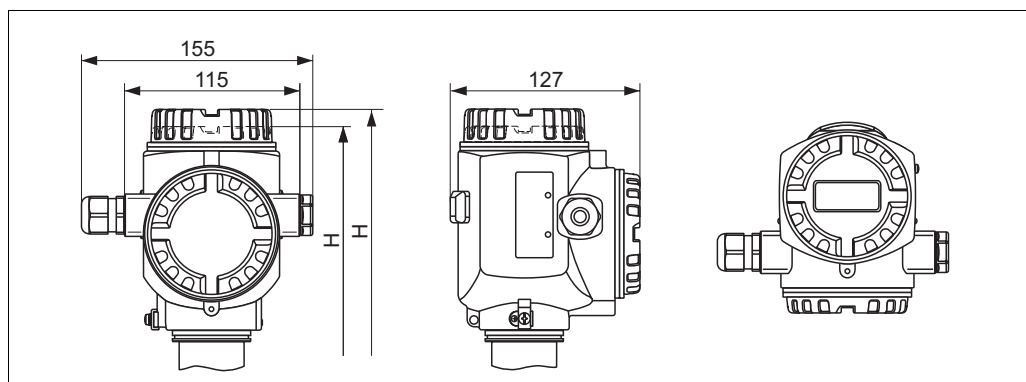

Front view, left-hand side view, top view.

→ See appropriate process connection for installation height H . For housing weight see Page 31.

Dimensions of T17 housing

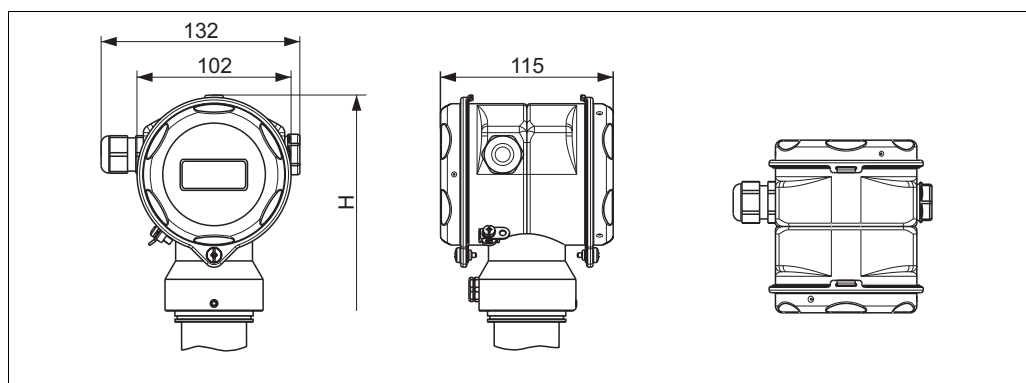

Front view, left-hand side view, top view.

→ See appropriate process connection for installation height H . For housing weight see Page 31.

Process connections

Threaded connection ISO 228 and NPT

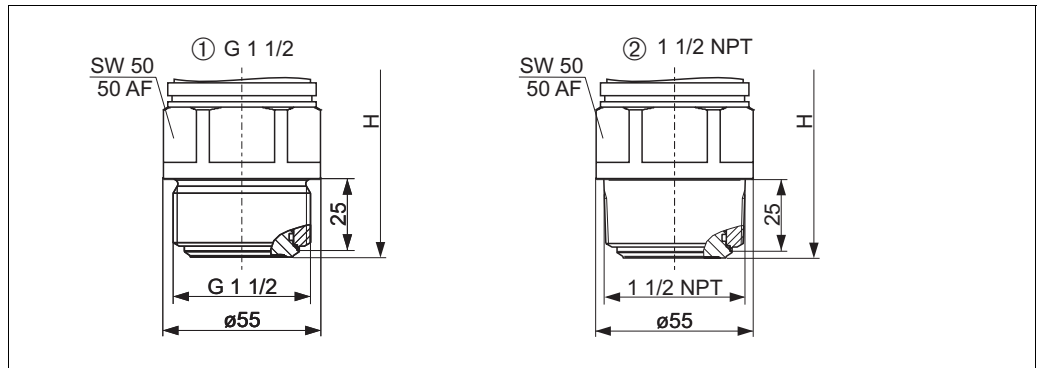

P01-FMB70xxx-06-09-xx-xx-004

FMB70 with thread,

→ See following table for installation height. For weight see Page 31.

- 1 Thread ISO 228 G 1 1/2 A;
Material version 1G: AISI 316L/1.4435, version 1H: Alloy C276/2.4819
- 2 Thread ANSI 1 1/2 MNPT;
Material version 2D: AISI 316L/1.4435

Installation height H for devices with threaded connection

Description	Device height H
T14 housing, optional display on the side	185 mm
T15 housing, optional display on top, flat cover	191 mm
T15 housing, optional display on top, high cover	202 mm
T17 housing, optional display on the side	201 mm

EN/DIN flanges, connection dimensions as per EN 1092-1/DIN 2527

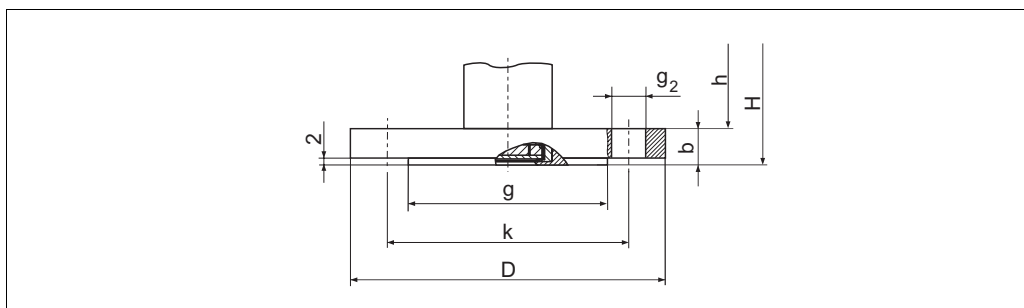

P01-FMB70xxx-06-09-xx-xx-002

FMB70, EN/DIN flange with raised face

Surface roughness of the surfaces in contact with the medium EN/DIN:

$R_a = 10$ to $12.5 \mu\text{m}$, ANSI: $R_a = 3.2$ to $6.3 \mu\text{m}$, JIS: $R_a = 3.2$ to $6.3 \mu\text{m}$

H: Device height = Height of the device without flange + flange thickness b

→ height h see Page 29.

Version	Flange								Boltholes			Flange weight ³ [kg]
	Material ¹	Nominal diameter	Nominal pressure	Shape ²	Diameter	Thick-ness	Raised face diameter	Raised face height	Quantity	Diameter	Hole circle	
					D [mm]	b [mm]	g [mm]	f [mm]		g ₂ [mm]	k [mm]	
CE	AISI 316L	DN 40	PN 10/16	B1 (C)	150	18	88	2	4	18	110	2.6
CF	AISI 316L	DN 50	PN 10/16	B1 (C)	165	18	102	2	4	18	125	3.3
CG	AISI 316L	DN 80	PN 10/16	B1 (C)	200	20	138	2	8	18	160	5.1
CH	AISI 316L	DN 100	PN 10/16	B1 (C)	220	20	158	2	8	18	180	6.3

1) AISI 316L/1.4435

2) Designation as per DIN 2526 in brackets

3) Weight incl. pipe and measuring cell, housing weight, see Page 31

ANSI flanges, connection dimensions as per ANSI B 16.5, raised face RF

Flange								Boltholes			
Version	Material ¹	Nominal diameter	Class	Diameter	Thickness	Raised face diameter	Raised face height	Quantity	Diameter	Hole circle	Flange weight ²
		[in]	[lb./sq in]	D [in] [mm]	b [in] [mm]	g [in] [mm]	f [in] [mm]		g ₂ [in] [mm]	k [in] [mm]	[kg]
AE	AISI 316/ 316L	1 1/2	150	5 127	0.69 17.5	2.88 73.2	0.06 1.6	4	0.62 15.7	3.88 98.6	2.1
AF	AISI 316/ 316L	2	150	6 152.4	0.75 19.1	3.62 91.9	0.06 1.6	4	0.75 19.1	4.75 120.7	3.0
AG	AISI 316/ 316L	3	150	7.5 190.5	0.94 23.9	5 127	0.06 1.6	4	0.75 19.1	6 152.4	5.7
AH	AISI 316/ 316L	4	150	9 228.6	0.94 23.9	6.19 157.2	0.06 1.6	8	0.75 19.1	7.5 190.5	7.8

- 1) Combination of AISI 316 for required pressure resistance and AISI 316L for required chemical resistance (dual rated)
- 2) Weight incl. pipe and measuring cell, housing weight, see Page 31

JIS flanges, connection dimensions as per JIS B 2220, raised face RF

Flange								Boltholes			
Version	Material ¹	Nominal diameter	Nominal pressure	Diameter	Thickness	Raised face diameter	Raised face height	Quantity	Diameter	Hole circle	Flange weight ²
				D [mm]	b [mm]	g [mm]	f [mm]		g ₂ [mm]	k [mm]	[kg]
7B	AISI 316L	40 A	10 K	140	16	81	2	4	19	105	2.1
7C	AISI 316L	50 A	10 K	155	16	96	2	4	19	120	2.5
7D	AISI 316L	80 A	10 K	185	18	126	2	8	19	150	3.8
7L	AISI 316L	100 A	10 K	210	18	151	2	8	19	175	4.9

- 1) AISI 316L/1.4435
- 2) Weight incl. pipe and measuring cell, housing weight, see Page 31

Installation height H for devices with flange

Description	Device height H
T14 housing, optional display on the side	190 mm
T15 housing, optional display on top, flat cover	196 mm
T15 housing, optional display on top, high cover	205 mm
T17 housing, optional display on the side	206 mm

Hygienic connections

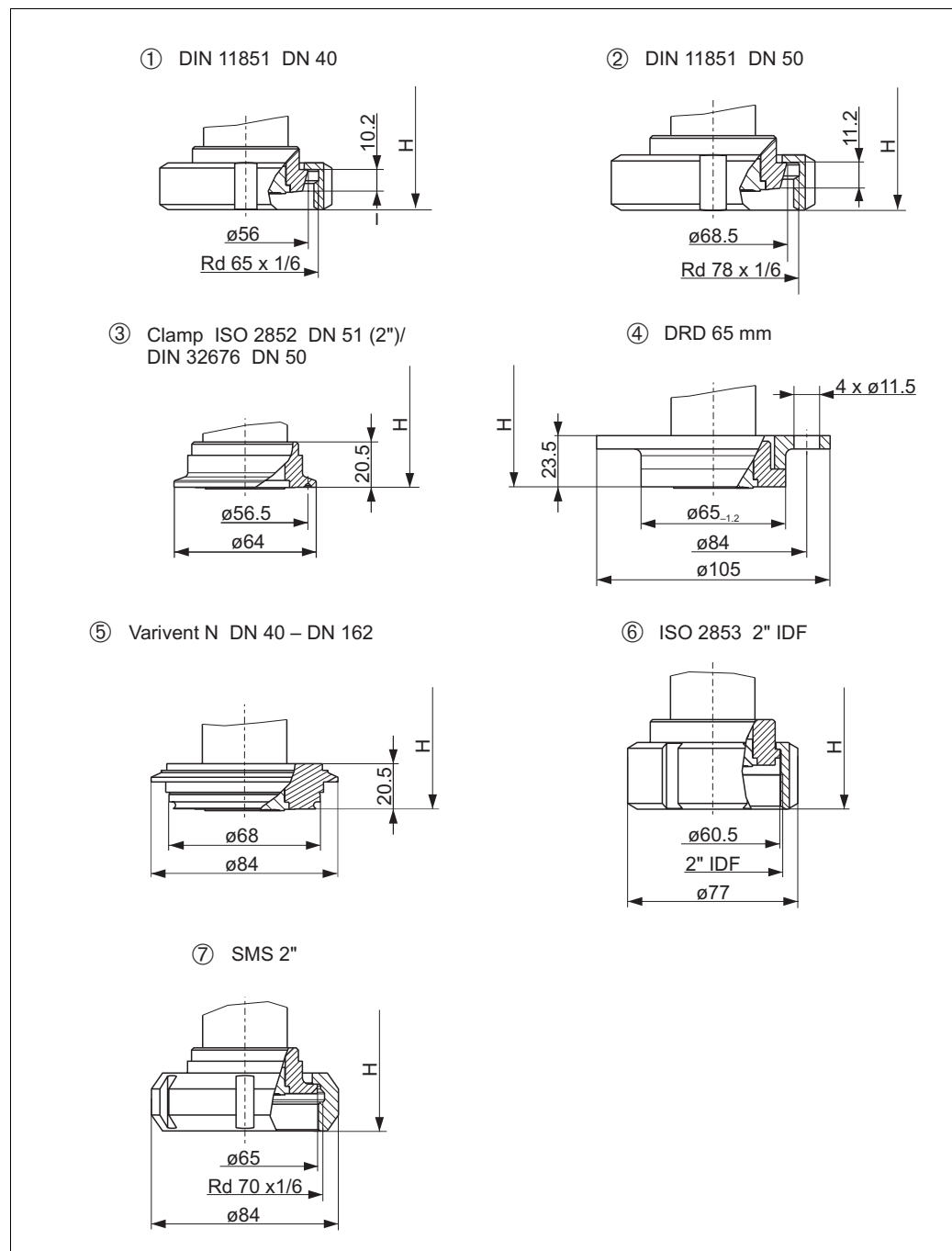

P01-FMB70xxx-06-09-xx-xx-001

FMB70 process connections, hygienic connections, material AISI 316L/1.4435

surface roughness of the surfaces in contact with the medium $\leq 0.8 \mu\text{m}$ as standard. Lower surface roughness on request.

→ For weight see Page 31.

- 1 Version M2: DIN 11851 DN 40 PN 25, 3A
- 2 Version M3: DIN 11851 DN 50 PN 25, 3A
- 3 Version TD: Tri-Clamp ISO 2852 DN 40 – DN 51 (2"), DN 32675 DN 50, EHEDG, 3A
- 4 Version TK: DRD 65 mm PN 25, 3A
- 5 Version TR: Varivent type N for pipes 40 – 162, PN 40, EHEDG, 3A
- 6 Version UE: SMS 2", PN25, EHEDG, 3A
- 7 Version 56: ISO 2853 2" IDF, EHEDG, 3A

Installation height H for devices with hygiene connection

Description	Device height H
T14 housing, optional display on the side	188 mm
T15 housing, optional display on top, flat cover	194 mm
T15 housing, optional display on top, high cover	203 mm
T17 housing, optional display on the side	204 mm

Universal process adapter

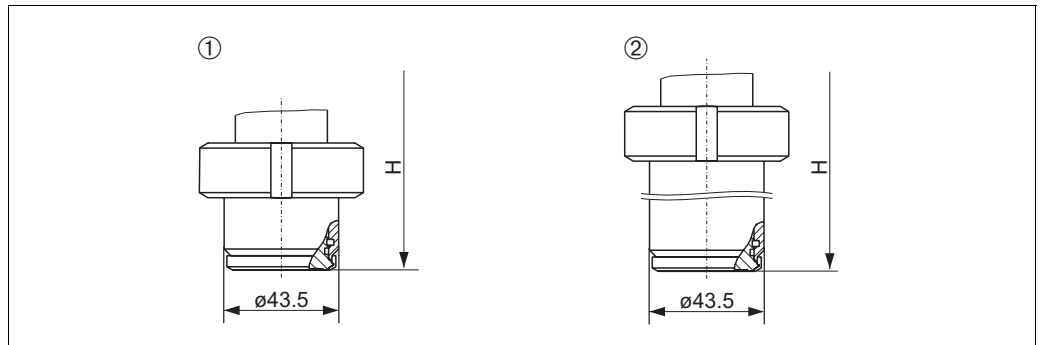

P01-FMB70xxx-00-09-xx-xx-003

FMB70 process connection, material: AISI 316L/1.4435;

Surface roughness of the surfaces in contact with the medium $R_a \leq 0.8 \mu\text{m}$ as standard. Lower surface roughness on request.

1 Version 00: universal process adapter incl. silicone molded seal, 3A, EHEDG

2 Version 57: universal process adapter, extension 6 inch including silicone molded seal, 3A, EHEDG

Installation height H for devices with universal process adapter

Description	Device height H, universal process adapter	Device height H, universal process adapter, 6 inch extension
T14 housing, optional display on the side	197 mm	308 mm
T15 housing, optional display on top, flat cover	203 mm	314 mm
T15 housing, optional display on top, high cover	214 mm	325 mm
T17 housing, optional display on the side	213 mm	324 mm

Weight

Housing

	T14	T15	T17
	Aluminum	Aluminum	AISI 316L/1.4404
with electronics insert and on-site display	1.2 kg	1.8 kg	1.2 kg
with electronics insert, without on-site display	1.1 kg	1.7 kg	1.1 kg

Process connections

- Version 1G, thread ISO 228 G 1 1/2 A, AISI 316L/1.4435: 0.8 kg
- Version 1H, thread ISO 228 G 1 1/2 A, Alloy C276/2.4819: 0.8 kg
- Version 2D, thread ANSI 1 1/2 MNPT, AISI 316L/1.4435: 0.8 kg
- Version M2: DIN 11851 DN 40 PN 25, AISI 316L/1.4435: 0.7 kg
- Version M3: DIN 11851 DN 50 PN 25, AISI 316L/1.4435: 0.9 kg
- Version TD: Tri-Clamp ISO 2852 DN 40 – DN 51 (2"), DN 32675 DN 50, AISI 316L/1.4435: 0.7 kg
- Version TK: DRD 65 mm PN 25, , AISI 316L/1.4435: 1.1 kg
- Version TR: Varivent type N for pipes 40 – 162, PN 40, AISI 316L/1.4435: 1.0 kg
- Version UE: SMS 2", PN25, AISI 316L/1.4435: 0.7 kg
- Version 56: ISO 2853 2" IDF, AISI 316L/1.4435: 0.8 kg
- Version 00: Universal process adapter, AISI 316L/1.4435: 0.8 kg
- Version 57: Universal process adapter with 6 inch extension, AISI 316L/1.4435: 1.7 kg
- → Flanges, see Page 28 ff.

Material**T14/T15 housing:**

- Housing: Die-cast aluminium with protective powder-coating on polyester basis: RAL 5012 (blue), cover: RAL 7035 (grey)
- External operation (keys and key covering): Polycarbonate PC-FR Lexan UL 940 UL94VO, RAL 7035 (grey)
- Sight glass: Version for non-hazardous area 1/2 G EEx ia, IS, NI: Polycarbonate (PC); 3 G EEx nA, 1/2 D, 1/3 D, 1 GD, 1/2 GD, DIP, Dust Ex: Mineral glass
- Cable gland: Polyamide (PA)
- Blind plug: PBT-GF30 FR, Dust Ex: AISI 316L (1.4435)
- Cable and blind plug seal: Silicone (VMQ)
- Pressure compensation filter: PA6 GF10, O-ring: Silicone (VMQ)
- O-ring for cover sealing: EPDM
- Nameplate: AISI 304 (1.4301)

T17 housing:

- Housing: Stainless steel AISI 316L (1.4404)
- Sight glass: Version for non-hazardous area 1/2 G EEx ia, IS, NI: Polycarbonate (PC); 3 G EEx nA, 1/2 D, 1/3 D, 1 GD, 1/2 GD, DIP, Dust Ex: Mineral glass
- Cable gland: Polyamide (PA), Dust Ex: CuZn nickel-plated
- Blind plug: PBT-GF30 FR, Dust Ex: AISI 316L (1.4435)
- Cable and blind plug seal: Silicone (VMQ)
- Pressure compensation filter: PA6 GF10, O-ring: Silicone (VMQ)
- O-ring for cover sealing: Silicone (VMQ)
- Nameplates: lasered

Other:

- Mounting accessories: mounting kit with screws AISI 304 (1.4301)
- Process diaphragm: Alloy C276 (2.4819)

→ For process connections and filling oils, see ordering information, Page 34 ff.

Certificates and approvals

CE mark	The device meets the legal requirements of the relevant EC directive. Endress+Hauser confirms that the device has been successfully tested by applying the CE mark.
Ex approvals	All explosion protection data are given in separate documentation which is available upon request. The Ex documentation is supplied as standard with all devices approved for use in explosion hazardous areas. → See also Page 39 ff, "Safety Instructions" and "Installation/Control Drawings" sections.
Overfill protection	Overfill protection: WHG (German Water Resources Act)
Standards and guidelines	DIN EN 60770 (IEC 60770): Transmitters for use in industrial-process control systems Part 1: Methods for inspection and routine testing DIN 16086: Electrical pressure measuring instruments, pressure sensors, pressure transmitters, pressure measuring instruments, concepts, specifications in data sheets EN 61326: Electrical equipment for measurement, control and laboratory use – EMC requirements

Ordering information

FMB70

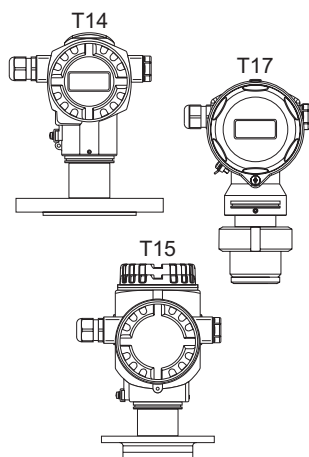
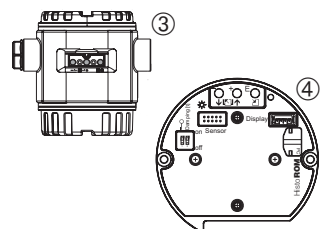
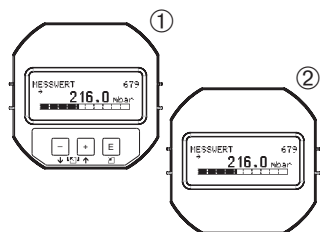

10	Approval:																		
	A Version for non-hazardous areas F Version for non-hazardous areas, WHG overfill protection 1 ATEX II 1/2 G EEx ia IIC T6 6 ATEX II 1/2 G EEx ia IIC T6, WHG overfill protection 2 ATEX II 1/2 D 4 ATEX II 1/3 D 8 ATEX II 1 GD EEx ia IIC T6 3 ATEX II 1/2 GD EEx ia IIC T6 7 ATEX II 3 G EEx nA II T6 S FM IS, Class I, II, III Division 1, Groups A – G; NI Class I Division 2, Groups A – D; AEx ia Q FM DIP, Class II, III Division 1, Groups E – G R FM NI, Class I, Division 2, Groups A – D U CSA IS, Class I, II, III Division 1, Groups A – G W CSA Class II, III Division 1, Groups E – G (Dust Ex) K TIIS Ex ia IIC T6																		
20	Output; Operation:																		
	A 4...20 mA HART, operation outside, LCD (→ see Fig. ①, ③) B 4...20 mA HART, operation inside, LCD (→ see Fig. ①, ④) C 4...20 mA HART, operation inside (→ see Fig. ④) M PROFIBUS PA, operation outside, LCD (→ see Fig. ②, ③) N PROFIBUS PA, operation inside, LCD (→ see Fig. ②, ④) O PROFIBUS PA, operation inside (→ see Fig. ④) P FOUNDATION Fieldbus, operation outside, LCD (→ see Fig. ②, ④) Q FOUNDATION Fieldbus, operation inside, LCD (→ see Fig. ②, ④) R FOUNDATION Fieldbus, operation inside (→ see Fig. ④)																		
30	Housing; Cable entry; Protection:																		
	A Aluminum T14 housing, optional display on the side, IP 66/67/NEMA 6P, Gland M 20x1.5 B Aluminum T14 housing, optional display on the side, IP 66/67/NEMA 6P, Thread G 1/2 C Aluminum T14 housing, optional display on the side, IP 66/67/NEMA 6P, Thread 1/2 NPT D Aluminum T14 housing, optional display on the side, IP 66/67/NEMA 6P, M 12x1 PA plug E Aluminum T14 housing, optional display on the side, IP 66/67/NEMA 6P, 7/8" FF plug F Aluminum T14 housing, optional display on the side, IP 65/NEMA 4X, Han7D connector, 90° J Aluminum T15 housing, optional display on the top, IP 66/67/NEMA 6P, Gland M 20x1.5 K Aluminum T15 housing, optional display on the top, IP 66/67/NEMA 6P, Thread G 1/2 L Aluminum T15 housing, optional display on the top, IP 66/67/NEMA 6P, Thread 1/2 NPT M Aluminum T15 housing, optional display on the top, IP 66/67/NEMA 6P, M 12x1 PA plug N Aluminum T15 housing, optional display on the top, IP 66/67/NEMA 6P, 7/8" FF plug P Aluminum T15 housing, optional display on the top, IP 65/NEMA 4X, Han7D connector, 90° R AISI 316L T17 housing, optional display on the side, IP 66/68/NEMA 6P, Gland M 20x1.5 S AISI 316L T17 housing, optional display on the side, IP 66/68/NEMA 6P, Thread G 1/2 T AISI 316L T17 housing, optional display on the side, IP 66/68/NEMA 6P, Thread 1/2 NPT U AISI 316L T17 housing, optional display on the side, IP 66/68/NEMA 6P, M 12x1 PA plug V AISI 316L T17 housing, optional display on the side, IP 66/68/NEMA 6P, 7/8" FF plug																		
40	Sensor range; Sensor overload limit (= OPL):																		
	Sensors for gauge pressure Measuring limits: -100 % (min. -0.9 bar)...+100 % of sensor rated value																		
	<table border="1"> <thead> <tr> <th></th> <th>Sensor rated value (URL)</th> <th>OPL (over pressure limit)</th> </tr> </thead> <tbody> <tr> <td>1C</td> <td>100 mbar/10 kPa/1.5 psi/1 mH₂O/40 inH₂O</td> <td>4 bar/400 kPa/60psi/40 mH₂O/160 inH₂O</td> </tr> <tr> <td>1F</td> <td>400 mbar/40 kPa/60psi/4 mH₂O/160 inH₂O</td> <td>8 bar/800 kPa/120 psi/80 mH₂O/3200 inH₂O</td> </tr> <tr> <td>1H</td> <td>1.2 bar/120 kPa/18 psi/12 mH₂O/480 inH₂O</td> <td>25 bar/2.5 MPa/375 psi/250 mH₂O/10000 inH₂O</td> </tr> <tr> <td>1M</td> <td>4 bar/400 kPa/60 psi/40 mH₂O/1600 inH₂O</td> <td>25 bar/2.5 MPa/375 psi/250 mH₂O/10000 inH₂O</td> </tr> <tr> <td>1P</td> <td>10 bar/1 MPa/150 psi/100 mH₂O/4000 inH₂O</td> <td>40 bar/4 MPa/600 psi/400 mH₂O/16000 inH₂O</td> </tr> </tbody> </table>		Sensor rated value (URL)	OPL (over pressure limit)	1C	100 mbar/10 kPa/1.5 psi/1 mH ₂ O/40 inH ₂ O	4 bar/400 kPa/60psi/40 mH ₂ O/160 inH ₂ O	1F	400 mbar/40 kPa/60psi/4 mH ₂ O/160 inH ₂ O	8 bar/800 kPa/120 psi/80 mH ₂ O/3200 inH ₂ O	1H	1.2 bar/120 kPa/18 psi/12 mH ₂ O/480 inH ₂ O	25 bar/2.5 MPa/375 psi/250 mH ₂ O/10000 inH ₂ O	1M	4 bar/400 kPa/60 psi/40 mH ₂ O/1600 inH ₂ O	25 bar/2.5 MPa/375 psi/250 mH ₂ O/10000 inH ₂ O	1P	10 bar/1 MPa/150 psi/100 mH ₂ O/4000 inH ₂ O	40 bar/4 MPa/600 psi/400 mH ₂ O/16000 inH ₂ O
	Sensor rated value (URL)	OPL (over pressure limit)																	
1C	100 mbar/10 kPa/1.5 psi/1 mH ₂ O/40 inH ₂ O	4 bar/400 kPa/60psi/40 mH ₂ O/160 inH ₂ O																	
1F	400 mbar/40 kPa/60psi/4 mH ₂ O/160 inH ₂ O	8 bar/800 kPa/120 psi/80 mH ₂ O/3200 inH ₂ O																	
1H	1.2 bar/120 kPa/18 psi/12 mH ₂ O/480 inH ₂ O	25 bar/2.5 MPa/375 psi/250 mH ₂ O/10000 inH ₂ O																	
1M	4 bar/400 kPa/60 psi/40 mH ₂ O/1600 inH ₂ O	25 bar/2.5 MPa/375 psi/250 mH ₂ O/10000 inH ₂ O																	
1P	10 bar/1 MPa/150 psi/100 mH ₂ O/4000 inH ₂ O	40 bar/4 MPa/600 psi/400 mH ₂ O/16000 inH ₂ O																	
FMB70	Order code																		

→ For continuation of ordering information for FMB70, see the following page.

FMB70 – (continued)

50					Calibration; Unit:	
	A	Sensor range; %				
	1	Sensor range; mbar/bar				
	2	Sensor range; kPa/MPa				
	3	Sensor range; mmH ₂ O/mH ₂ O				
	4	Sensor range; inH ₂ O/ftH ₂ O				
	6	Sensor range; psi				
	B	Customised; see additional specification				
	C	Factory calibration certificate, 5-point; see additional specification				
	D	DKD certificate; see additional specification				
60					Diaphragm material; Seal:	
	2	Alloy C276; welded				
	6	Alloy C276 with gold-rhodium coating; welded				
70					Process connection; Material:	
		Threaded connection				
	1G	Thread ISO 228 G 1 1/2, AISI 316L				
	1H	Thread ISO 228 G 1 2/2, Alloy C				
	2D	Thread ANSI MNPT 1 1/2, AISI 316L				
	EN/DIN flanges					
	CE	DN 40 PN 10/16 B1, AISI 316L				
	CF	DN 50 PN 10/16 B1, AISI 316L				
	CG	DN 80 PN 10/16 B1, AISI 316L				
	CH	DN 100 PN 10/16 B1, AISI 316L				
	ANSI flanges					
	AE	1 1/2" 150 lbs RF, AISI 316/316L				
	AF	2" 150 lbs RF, AISI 316/316L				
	AG	3" 150 lbs RF, AISI 316/316L				
	AH	4" 150 lbs RF, AISI 316/316L				
	JIS flanges					
	KE	10 K 40 A RF, AISI 316L				
	KF	10K 50A RF, AISI 316L				
	KL	10K 80A RF, AISI 316L				
	KH	10K 100A RF, AISI 316L				
	Hygienic connections					
	M2	DIN 11851 DN 40 PN 25, AISI 316L, 3A				
	M3	DIN 11851 DN 50 PN25, AISI 316L, 3A				
	TD	Tri-Clamp ISO 2852 DN 40 – DN 51 (2"), DIN 32676 DN 50, AISI 316L, EHEDG, 3A				
	TK	DRD 65 mm PN 25, AISI 316L, 3A				
	TR	Varivent type N for DN 40 – DN 162 pipes, EHEDG, 3A				
	UE	SMS 2" PN 25, AISI 316L, EHEDG, 3A				
	56	ISO 2853 2" IDF, AISI316L, EHEDG, 3A				
	00	Universal process adapter 44 mm including silicon molded seal, EHEDG, 3A				
	57	Universal process adapter 44 mm, 6" extension including silicon molded seal, EHEDG, 3A				
90					Filling:	
	C	Mineral oil (FDA)				
	F	Inert oil				
100					Additional option 1:	
	A	not selected				
	E	SIL2/IEC61508 Declaration of conformity				
	B	Material test certificate for wetted parts, inspection certificate as per EN 10204 3.1 acc. to specification 52005759				
	M	Overvoltage protection				
	N	HistoROM/M-DAT				
	S	GL (German Lloyd) marine certificate				
	2	Test report acc. to EN 10204 2.2				
	3	Routine test with certificate, inspection certificate as per EN 10204 3.1				
	4	Overpressure test with certificate, inspection certificate as per EN 10204 3.1				
FMB70						Order code

→ For continuation of ordering information for FMB70, see the following page.

FMB70 – (continued)

110										Additional option 2:	
										A	not selected
										E	SIL2/IEC61508 Declaration of conformity
										M	Overvoltage protection
										N	HistoROM/M-DAT
										S	GL (German Lloyd) marine certificate
										U	Mounting bracket, pipe/wall mounting, AISI 304
										2	Test report acc. to EN 10204 2.2
										3	Routine test with certificate, inspection certificate as per EN 10204 3.1
										4	Overpressure test with certificate, inspection certificate as per EN 10204 3.1
FMB70										Complete order code	

Accessories

Welding flanges

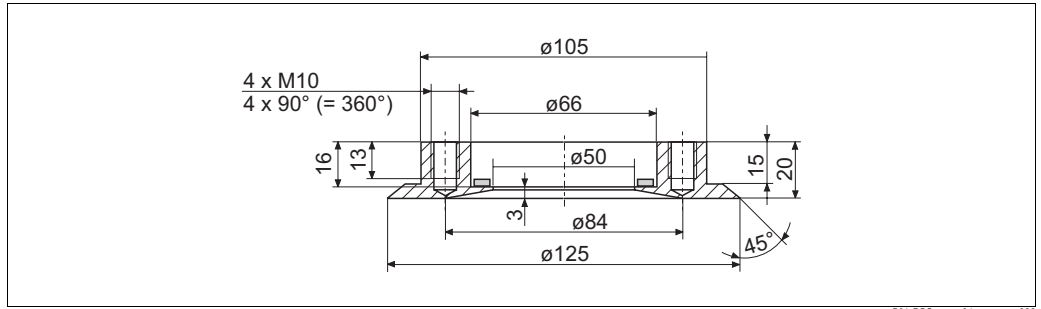

P01-DB5xxxx-06-xx-xx-xx-032

Welding flange for flush-mounted installation for devices with a DRD flange.

Version	Order number
DRD DN 50, AISI 316L (1.4435)	52002041
DRD DN 50, 3.1, AISI 316L (1.4435)	52011899
DRD DN 50, AISI 304 (1.4301)	916743-0000

Note

- Order number for a replacement PTFE flat seal: 916783-0000

Welding neck for universal process adapter

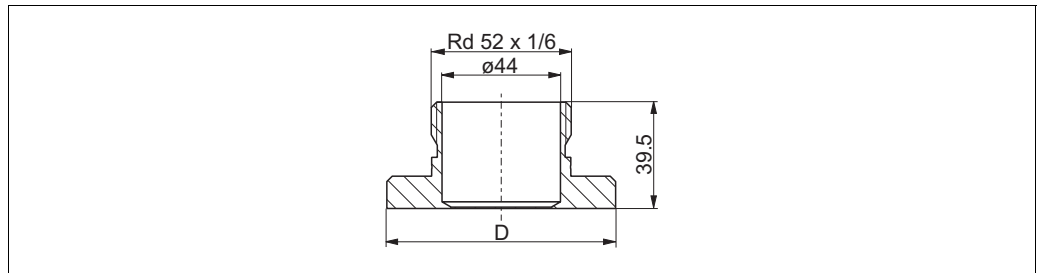

P01-PMC45xxx-06-xx-xx-xx-000

Welding neck for flush mounting a Deltapilot S DB50L/DB50S with a universal process adapter

Diameter D	Material	Order number
65 mm	AISI 316L	214880-0002
65 mm	AISI 316L with inspection certificate EN 10204 3.1 material	52010174
85 mm	AISI 316L	52006262
85 mm	AISI 316L with inspection certificate EN 10204 3.1 material	52010173

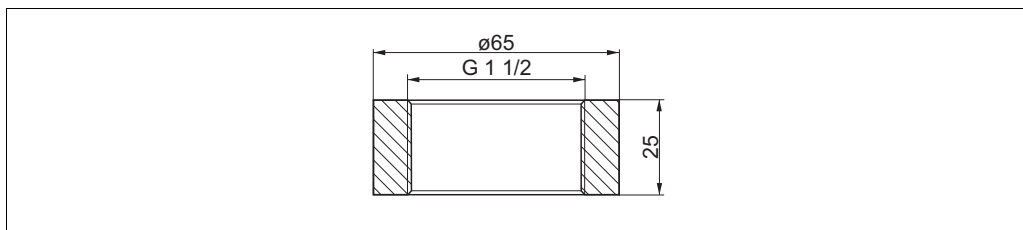
**Welding neck for
ISO G 1 1/2 thread**

P01-PMx4xxxx-06-09-xx-xx-000

Welding neck for flush mounting a Deltapilot S DB50 with ISO 228 G 1 1/2 A thread
Order number: 52024469, order number with 3.1 inspection certificate: 52024470

Note

- Endress+Hauser offers a pressure sensor dummy for the welding necks with order numbers 52024469 and 52024470. Order number for pressure sensor dummy: 52024471

Adapter

You can use the following adapters to mount an FMB70 with a universal process connection in a DRD, dairy fitting or clamp connection:

Version	Order number
DRD 65 mm, AISI 304 (1.4301)	917656-0001
Dairy fitting DIN 11851 DN 40, AISI 304 (1.4301)	917656-0002
Dairy fitting DIN 11851 DN 50, AISI 304 (1.4301)	917656-0000
Tri-Clamp ISO 2852 DN 40-51 (2")/DIN 32676 DN 50, AISI 304 (1.4301)	917650-0002

HistoROM®/M-DAT

HistoROM®/M-DAT is a memory module, which is attached to the electronic insert. The HistoROM®/M-DAT can be retrofitted at any stage. The HistoROM®/M-DAT can be retrofitted at any time → For further information see Page 11.

- Order number: 52027785

Mounting bracket

Endress+Hauser offers a mounting bracket for installing the device on pipes or on walls.
→ See also Page 22, "Wall and pipe mounting".

- Material: AISI 304 (1.4301)
- Order number: 52024612

M 12x1 plug sockets

Endress+Hauser offers for devices with M12 plug the following accessories:

Plug-in jack M 12x1, straight

- Material: Body PA; coupling nut CuZn, nickel-plated
- Degree of protection (fully locked): IP67
- Order number: 52006263

Plug-in jack M 12x1, elbowed

- Material: Body PBT/PA; coupling nut GD-Zn, nickel-plated
- Degree of protection (fully locked): IP67
- Order number: 51006327

Cable 4x0.34 mm² with M12 socket, elbowed, screw plug, 5 m length

- Material: Body PUR; coupling nut CuSn/Ni; cable PVC
- Degree of protection (fully locked): IP67
- Order number: 52010285

Documentation

Innovation	<ul style="list-style-type: none"> ■ Hydrostatic pressure sensor – watertight, condensation-free measuring cell: IN011P/00/de
Field of activities	<ul style="list-style-type: none"> ■ Pressure measurement, Powerful instruments for process pressure, differential pressure, level and flow: FA004P/00/en
Technical information	<ul style="list-style-type: none"> ■ EMC test procedures TI241F/00/en
Operating instructions	<p>4 to 20 mA HART:</p> <ul style="list-style-type: none"> ■ Deltapilot S: BA332P/00/en ■ Description of device functions Cerabar S/Deltabar S/Deltapilot S, pressure and differential pressure transmitter: BA274P/00/en
Functional safety manual (SIL)	<ul style="list-style-type: none"> ■ Deltapilot S (4 to 20 mA): SD213P/00/en

Safety instructions	Certificate/explosion protection	Device	Electronics	Documentation
	ATEX II 1/2 G EEx ia IIC T6	FMB70	– 4...20 mA HART, PROFIBUS PA, FOUNDATION Fieldbus	– XA283P
	ATEX II 1/2 D		– 4...20 mA HART, PROFIBUS PA, FOUNDATION Fieldbus	– XA284P
	ATEX II 1/3 D		– 4...20 mA HART, PROFIBUS PA, FOUNDATION Fieldbus	– XA285P
	ATEX II 1 GD EEx ia IIC T6		– 4...20 mA HART, PROFIBUS PA, FOUNDATION Fieldbus	– XA287P
	ATEX II 1/2 GD EEx ia IIC T6		– 4...20 mA HART, PROFIBUS PA, FOUNDATION Fieldbus	– XA286P
	ATEX II 3 G EEx nA II T6		– 4...20 mA HART, PROFIBUS PA, FOUNDATION Fieldbus	– XA288P

Installation/Control Drawings	Certificate/explosion protection	Device	Electronics	Documentation
	FM IS Class I, II, III, Division 1, Groups A – G; NI, Class I Division 2, Groups A – D; AEx ia	FMB70	– 4 to 20 mA HART – PROFIBUS PA, FOUNDATION Fieldbus	– ZD214P – ZD216P
	CSA IS Class I, II, III, Division 1, Groups A – G; Class I Division 2, Groups A – G		– 4 to 20 mA HART – PROFIBUS PA, FOUNDATION Fieldbus	– ZD215P – ZD217P

Overfill protection	<ul style="list-style-type: none"> ■ WHG: ZE266P/00/de
----------------------------	---

Deutschland

Endress+Hauser
Messtechnik
GmbH+Co. KG
Colmarer Str. 6
79576 Weil am Rhein
Fax 0800 EHFAXEN
Fax 0800 3 43 29 36
www.de.endress.com

Vertrieb

- Beratung
- Information
- Auftrag
- Bestellung

Tel. 0800 EHVERTRIEB
Tel. 0800 3 48 37 87
info@de.endress.com

Service

- Help-Desk
- Feldservice
- Ersatzteile/Reparatur
- Kalibrierung

Tel. 0800 EHSERVICE
Tel. 0800 3 47 37 84
service@de.endress.com

Technische Büros

- Hamburg
- Hannover
- Ratingen
- Frankfurt
- Stuttgart
- München
- Berlin

Österreich

Endress+Hauser
Ges.m.b.H.
Lehnergasse 4
1230 Wien
Tel. +43 1 88 05 60
Fax +43 1 88 05 63 35
info@at.endress.com
www.at.endress.com

Schweiz

Endress+Hauser
Metso AG
Sternenhofstraße 21
4153 Reinach/BL 1
Tel. +41 61 7 15 75 75
Fax +41 61 7 11 16 50
info@ch.endress.com
www.ch.endress.com

Endress+Hauser 

People for Process Automation